

SCREWED END NEW 2-PIECE FULL PORT BALL VALVE



V-2E TYPE

SIZE: 1/4"~4"



STAINLESS STEEL

AISI-316 (EN10213-4 1.4408) (ASTM-A351-CF8M)

AISI-304 (EN10213-4 1.4308) (ASTM-A351-CF8)

CARBON STEEL

S-20C (EN10213-2 1.0619) (ASTM-A216-WCB)

FEATURES:

*Pipe thread in accordance with ANSI B2.1, BS 21 1973, DIN 259/2999, ISO 228

*With mounting pad

*Blow-out proof stem/Full port

*Investment casting body and cap

*1000 PSI (69 BAR) W.O.G.

*Lug body

OPTION: Locking device

Drilling and Tapped Mounting Pad

ITEM	PARTS	Q.TY	MATERIALS	
1	BODY	1	ASTM-A351-CF8M	ASTM-A216-WCB
2	CAP	1	ASTM-A351-CF8M	ASTM-A216-WCB
3	BALL	1	ASTM-A351-CF8M	ASTM-A351-CF8
4	BALL SEAT	2	PTFE	PTFE
5	JOINT GASKET	1	PTFE	PTFE
6	STEM	1	AISI 316	AISI 304
7	THRUST WASHER	1	PTFE	PTFE
8	STEM PACKING	2	PTFE	PTFE
9	GLAND NUT	1	AISI 304	AISI 304
10	HANDLE	1	AISI 304	AISI 304
11	SPRING WASHER	1	AISI 304	AISI 304
12	STEM NUT	1	AISI 304	AISI 304
13	PLASTIC COVER	1	PLASTIC	PLASTIC
14	LOCK DEVICE	1	AISI 304	AISI 304

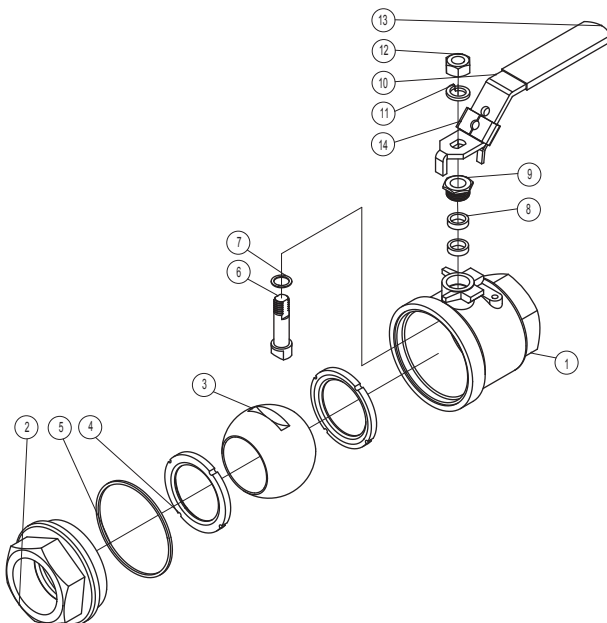
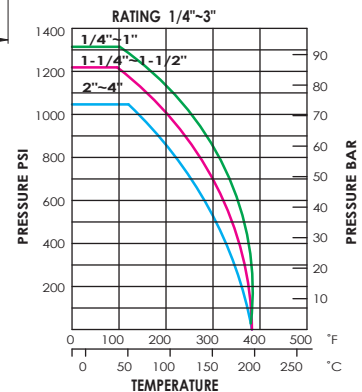
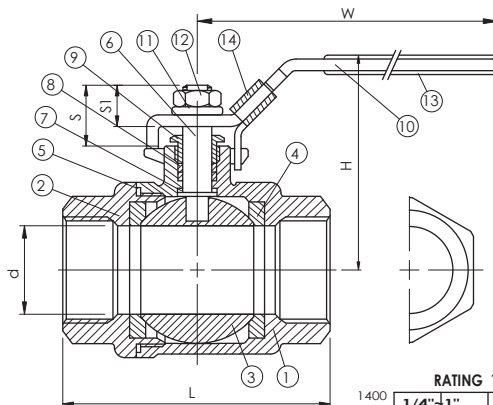
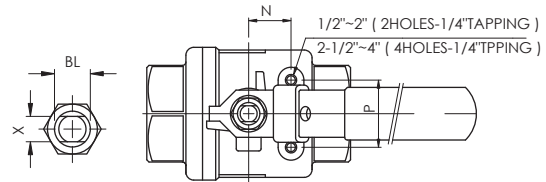

DIMENSIONS

UNIT:mm

NOMINAL SIZE	d	L	H	W	S	S1	X	N	P	BL	Cv FACTOR	TORQUE kgf-cm	KG
1/4"	11.6	44.5	51	95	16.8	10.2	5.0	12.5	25	5/16"	6.6	40	0.22
3/8"	12.7	44.5	51	95	16.8	10.2	5.0	12.5	25	5/16"	7.9	40	0.22
1/2"	15	57	53	95	16.8	10.2	5.0	12.5	25	5/16"	11.2	54	0.29
3/4"	20	65	59.5	110	21	13.5	6.5	21	24	3/8"	21	74	0.42
1"	25	76	73	135	24	16	8	22.5	33.5	7/16"	35	104	0.71
1-1/4"	32	87.5	79	135	25	16	8	23.5	38.1	7/16"	57	135	1.06
1-1/2"	38	102	90.5	165	26.5	17	9	23.5	38.1	1/2"	80	180	1.68
2"	50	123	98.5	165	26.5	17	9	23.5	38.1	1/2"	148	250	2.71
2-1/2"	65	156	130.5	215	41.5	29.5	12	35	56	3/4"	265	480	5.25
3"	80	184	142.5	215	41.5	29.5	12	35	56	3/4"	415	750	8.6
4"	100	250	173.5	325	47.5	36.5	16	50	63	1"	780	1100	19.32