

# Type 2000

2/2-way angle seat valve



## Operating Instructions

We reserve the right to make technical changes without notice.

© Bürkert Werke GmbH & Co. KG, 2008 - 2019

Operating Instructions 1908/17\_EUml 00893086 / Original DE

# CONTENTS

<b>1</b>	<b>About these instructions</b> .....	<b>5</b>
1.1	Symbols.....	5
1.2	Definition of terms .....	5
<b>2</b>	<b>Intended use</b> .....	<b>7</b>
<b>3</b>	<b>Basic safety instructions</b> .....	<b>8</b>
<b>4</b>	<b>General information</b> .....	<b>10</b>
4.1	Contact address .....	10
4.2	Warranty .....	10
4.3	Information on the Internet .....	10
<b>5</b>	<b>Product description</b> .....	<b>11</b>
5.1	Features.....	11
5.2	Structure and function.....	11
5.2.1	Flow direction below seat.....	13
5.2.2	Flow direction above the seat.....	13
5.3	Device options.....	13
5.4	Variants.....	14
<b>6</b>	<b>Technical data</b> .....	<b>15</b>
6.1	Conformity .....	15
6.2	Standards .....	15
6.3	Type label .....	15
6.3.1	Designation of the actuator size .....	15
6.4	Operating conditions .....	15
6.4.1	Temperature ranges.....	16
6.4.2	Pressure ranges .....	16
6.4.3	Minimum pilot pressure values .....	16
6.5	Mechanical data .....	20
<b>7</b>	<b>Installation</b> .....	<b>22</b>
7.1	Safety instructions installation.....	22
7.2	Preparatory work .....	23
7.2.1	Attach dirt trap.....	23
7.3	Installing valve body .....	23
7.4	Installing devices with welded connection.....	23
7.4.1	Removing actuator from the valve body for devices without control unit.....	23
7.4.2	Removing actuator from the valve body for devices with installed control unit.....	24
7.4.3	Installing actuator on valve body .....	24
7.5	Installing control unit .....	25
7.6	Turning actuator .....	25
7.6.1	Turning the actuator, devices with hexagon nut.....	25
7.7	Connecting device pneumatically .....	26
7.7.1	Connecting control medium .....	26

<b>8 Start-up</b> .....	<b>28</b>
<b>9 Deinstallation</b> .....	<b>29</b>
<b>10 Servicing</b> .....	<b>30</b>
10.1 Safety instructions maintenance .....	30
10.2 Maintenance work .....	30
10.2.1 Actuator .....	30
10.2.2 Wearing parts.....	30
10.2.3 Visual inspection.....	31
10.2.4 Cleaning.....	31
<b>11 Faults</b> .....	<b>32</b>
<b>12 Replacement parts, accessories</b> .....	<b>33</b>
12.1 Installation tools.....	33
12.2 Replacement part set .....	33
12.3 Spare parts for seal set for SET 5 actuator .....	34
12.4 Spare parts for valve set SET 6 .....	35
<b>13 Transportation, storage, disposal</b> .....	<b>37</b>

# 1 ABOUT THESE INSTRUCTIONS

The operating instructions describe the entire life cycle of the device.

→ Keep these instructions ready to hand at the operation site.



**Important safety information.**

- ▶ Carefully read these instructions.
- ▶ Observe in particular the safety instructions, intended use and operating conditions.
- ▶ Persons, who work on the device, must read and understand these instructions.

## 1.1 Symbols



**DANGER!**

Warns of an immediate danger.

- ▶ Failure to observe the warning will result in fatal or serious injuries.



**WARNING!**

Warns of a potentially dangerous situation.

- ▶ Failure to observe the warning may result in serious or fatal injuries.



**CAUTION!**

Warns of a possible danger.

- ▶ Failure to observe the warning may result in moderate or minor injuries.

### ATTENTION!

Warns of damage to property.

- ▶ Failure to observe the warning may result in damage to the device or system.



Indicates important additional information, tips and recommendations.



Refers to information in these instructions or in other documentation.

- ▶ Designates an instruction for risk prevention.

→ Designates a procedure which you must carry out.

- ✔ Indicates a result.

## 1.2 Definition of terms

In these instructions the term "device" denotes the following device types:

2/2-way angle seat valve Type 2000

The abbreviation "Ex" used in these instructions always stands for "potentially explosive atmosphere".

The term “büS” (Bürkert system bus) used in this manual refers to the communication bus developed by Bürkert, based on the CANopen protocol.

## 2 INTENDED USE



The angle seat valve Type 2000 is designed to control the flow rate of media. The permitted media are listed in the "Technical data".

- ▶ Use the device for its intended purpose only. Non-intended use of the device may be dangerous to people, nearby equipment and the environment.
- ▶ Correct transportation, correct storage as well as correct installation, commissioning, operation and maintenance are essential for reliable and problem-free operation.
- ▶ When using the device, observe the permitted data, operating conditions and application conditions. This information can be found in the contractual documents, the operating instructions and on the type label.
- ▶ Use the device only in conjunction with third-party devices and components recommended and authorized by Bürkert.
- ▶ In potentially explosive atmospheres, only use devices approved for use in those areas. These devices are labeled with a separate Ex type label. For such use, note the information provided on the separate Ex type label and the additional explosion-related information or separate explosion-related operating instructions.
- ▶ Protect device from environmental influences (e.g. radiation, air humidity, fumes). If you have any questions, contact your Bürkert sales department.

### 3 BASIC SAFETY INSTRUCTIONS

These safety instructions do not take into account any unforeseen circumstances and events which occur during installation, operation and maintenance.

The operator is responsible for observing the location-specific safety regulations, also with reference to the personnel.

#### **DANGER!**

Risk of injury from high pressure and discharge of medium.

- ▶ Before working on the device or system, switch off the pressure. Vent or drain lines.

#### **DANGER!**

Electric shock due to installed electrical component.

- ▶ Before working on the device or system, switch off the power supply. Secure against reactivation.
- ▶ Observe the applicable accident prevention and safety regulations for electrical devices.

#### **WARNING!**

Risk of injury when opening the actuator.

The actuator contains a spring under tension. When the actuator is opened, the spring will jump out and may cause injuries.

- ▶ Do not open the actuator.

#### **WARNING!**

Risk of injury due to moving parts.

- ▶ Do not reach into openings in the device.

#### **WARNING!**

Danger of burns and risk of fire.

Quickly switching actuators or hot medium may cause the surface of the device to become hot.

- ▶ Only touch the device while wearing protective gloves.
- ▶ Keep the device away from highly flammable substances and media.

#### **WARNING!**

Danger due to loud noises.

Depending on the usage conditions, the device may generate loud noises. Detailed information on the probability of loud noises is available from the respective sales department.

- ▶ Wear hearing protection when in the vicinity of the device.

#### **WARNING!**

Discharge of medium if packing gland worn.

- ▶ If media are hazardous, safeguard the environment around the discharge point.





To prevent injuries, observe the following:

- ▶ Secure device or plant to prevent unintentional activation.
- ▶ Only trained technicians may perform installation and maintenance work.
- ▶ Perform installation and maintenance with suitable tools only.
- ▶ Heavy equipment must only be transported, assembled, installed or dismantled with the help of a second person as appropriate and using suitable apparatus.
- ▶ Following interruption of the process, ensure that the process is restarted in a controlled manner.  
Observe sequence:
  1. Apply electrical or pneumatic supply.
  2. Charge with medium.
- ▶ Do not make any changes to the device and do not subject it to mechanical stress.
- ▶ Feed only those media, which are listed in the chapter "Technical data", into the medium ports.
- ▶ Operate the device only in perfect state and in consideration of the operating instructions.
- ▶ For applications planning and operation of the device, observe the plant-specific safety regulations.
- ▶ Observe the general rules of technology.
- ▶ The plant owner is responsible for the safe operation and handling of the plant.



To protect the environment, observe the following:

- ▶ The pilot exhaust air of the device may be contaminated by lubricants.

## **4 GENERAL INFORMATION**

### **4.1 Contact address**

#### **Germany**

Bürkert Fluid Control Systems

Sales Center

Christian-Bürkert-Str. 13–17

D-74653 Ingelfingen

Phone: + 49 (0) 7940 - 10 91 111

Fax: + 49 (0) 7940 - 10 91 448

E-mail: [info@burkert.com](mailto:info@burkert.com)

#### **International**

The contact addresses can be found on the back pages of the printed Quickstart. Also on the Internet at:

<http://www.burkert.com>

### **4.2 Warranty**

A precondition for the warranty is that the device is used as intended in consideration of the specified usage conditions.

### **4.3 Information on the Internet**

Operating instructions and data sheets for the Bürkert products can be found on the Internet at:

<https://www.burkert.com/en>

## 5 PRODUCT DESCRIPTION

The device is specially optimised for decentralised process automation and meets all the relevant requirements, even under difficult usage conditions.

Its design enables the easy integration of automation modules in all extension stages, whether they are electrical/optical position feedback, pneumatic control units, or even an integrated fieldbus interface. Long service life and high tightness are achieved by the tried and tested self-adjusting packing gland. The system, consisting of valve and automation module is distinguished by a compact and sleek design, integrated pilot air ducts, a high chemical resistance, the degrees of protection IP65 or IP67 as well as the NEMA protection class 4X.

The device uses neutral gases or air to control the flow rate of liquid or gaseous media, such as water, alcohol, oil, fuel, saline solution, hydraulic fluid, lye, organic solvent or vapour.

### 5.1 Features

- Actuator can be rotated steplessly by 360°
- Valve body made of stainless steel with threaded connection, clamp connection or welded connection
- Easy integration of automation modules
- High chemical resistance
- High tightness and long service life due to self-adjusting packing gland
- High flow values through flow rate-optimised valve body made of stainless steel
- High seat tightness by swivel plate
- Maintenance-free under normal conditions

### 5.2 Structure and function

The angle seat valve consists of a pneumatically actuated piston actuator and a 2-way valve body. The actuator is made of PA or PPS. The proven, self-adjusting packing gland guarantees a high degree of tightness. Valve bodies made of stainless steel or red bronze <sup>1</sup>.

Depending on the variant, the valve seat is connected in the direction of or against the medium flow. Spring force (SFA) or pneumatic pilot pressure (SFB and SFI) generate the closing force on the swivel plate. A spindle connected to the actuator piston transmits the force.

---

<sup>1</sup> not for seat size 80

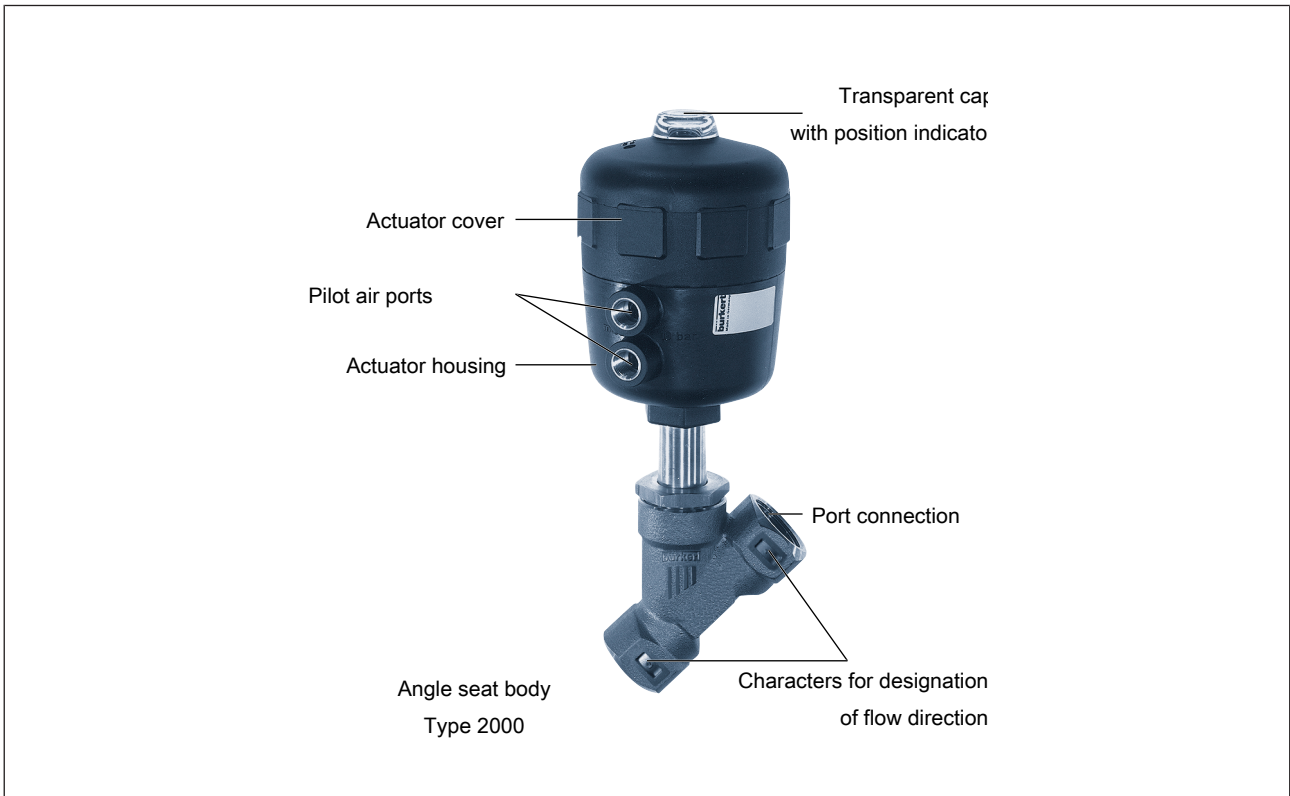

Fig. 1: Structure and description

Control function	Definition	Circuit symbol	Figure
A (CFA)	Closed by spring force in rest position.		
B (CFB)	Opened by spring force in rest position.		
I (CFI)	Actuating function via reciprocal pressurisation.		

Tab. 1: Control functions

### 5.2.1 Flow direction below seat

#### **WARNING!**

Valve seat leaking when control pressure is too low or medium pressure is too high.

If control pressure is too low for control function B and control function I or medium pressure is too high, the valve seat may leak.

- ▶ Observe values for minimum control pressure and maximum medium pressure.

Depending on the control function, the valve closes by spring force (control function A) or pilot pressure (control function B and I) against the medium flow.

As the medium is present under the swivel plate, the medium pressure contributes to the opening of the valve.

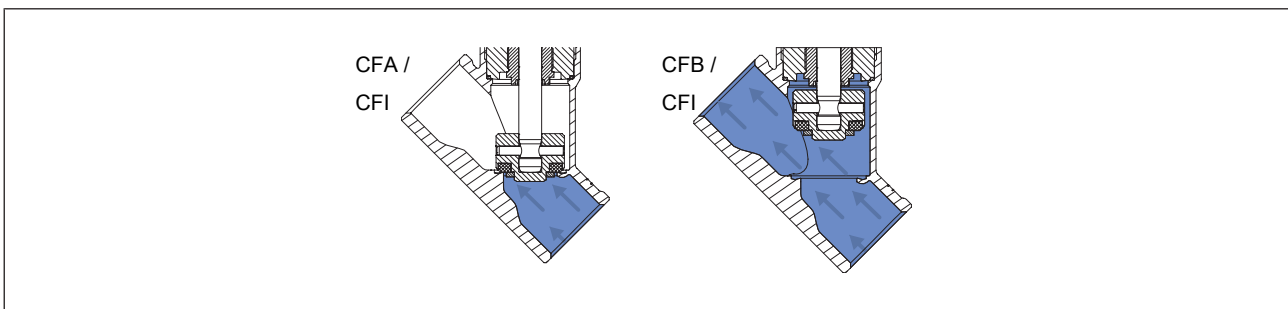

Fig. 2: Flow direction below seat, valve closes against medium flow

### 5.2.2 Flow direction above the seat

#### **DANGER!**

Risk of injury from rupturing lines and device when flow direction above the seat.

A pressure surge of liquid media may cause the lines and device to rupture.

- ▶ Do not use valves with flow direction above the seat for liquid media.

Flow direction above the seat is possible only on valves with control function A (closed by spring force in rest position)<sup>2</sup>.

The valve closes by spring force with the medium flow. As the medium is present above the swivel plate, the medium pressure contributes to the closing of the valve. The medium pressure also supports the sealing of the valve seat.

The valve opens by the pilot pressure.

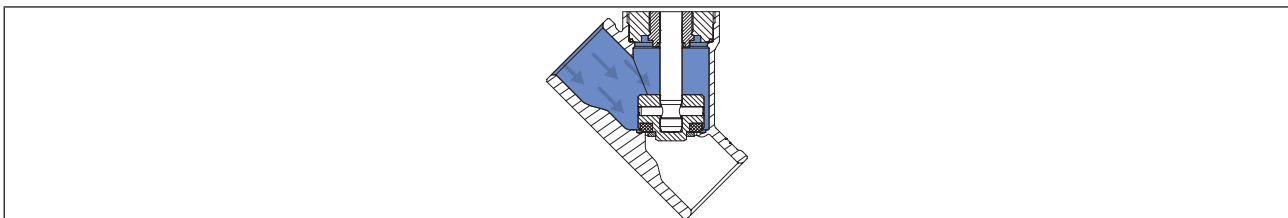

Fig. 3: Flow direction above the seat, valve closes with medium flow

## 5.3 Device options

- Stroke limit

Limiting the maximum or minimum flow rate volume with an adjusting screw.

<sup>2</sup>Not for seat size 80

- Control unit  
Different variants are available depending on the requirement.
- Position feedback  
The device is available with mechanical limit switches or inductive proximity switches.

## 5.4 Variants



Information on the variants of the device can be found in the data sheet at <https://www.burkert.com/en> or in your sales department.

## 6 TECHNICAL DATA

### 6.1 Conformity

The device conforms to the EC directives as per the EC Declaration of Conformity (if applicable).

### 6.2 Standards

The applied standards, which are used to demonstrate conformity with the directives, are listed in the EU type examination certificate and/or the EU Declaration of Conformity (if applicable).

### 6.3 Type label

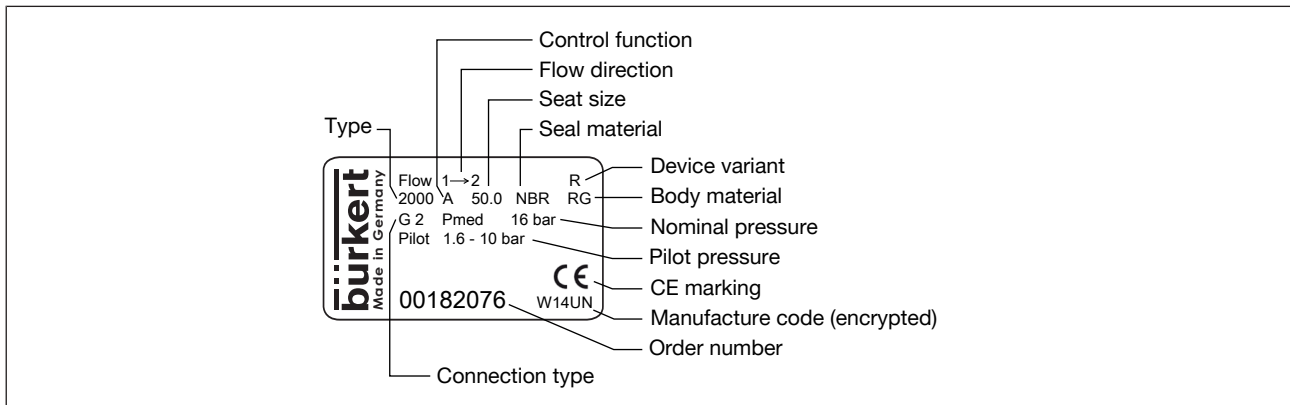

Fig. 4: Example of a type label

#### 6.3.1 Designation of the actuator size

Actuator size [mm]	Designation
ø40	C
ø50	D
ø63	E
ø80	R
ø100	G
ø125	H

Tab. 2: Designation of the actuator size

### 6.4 Operating conditions

Degree of protection	IP67 according to IEC 529 / DIN EN 60529
Flow media	Water, alcohols, oils, fuels, hydraulic fluids, saline solutions, lyes, organic solvents, vapour, air, neutral gases
Control media	Neutral gases, air
Sound pressure level	<70 dB(A)

The sound pressure level may be higher depending on the usage conditions

### 6.4.1 Temperature ranges

Actuator size [mm]	Actuator material	Medium temperature (with PTFE seal) [°C]	Ambient temperature <sup>3</sup> [°C]
ø40...ø63	PA	-10...see image below	-10...see image below
ø80...ø125	PA	-10...+180	-10...+60
ø40...ø80	PPS	-10...+180	+5...+140
ø125	PPS	-10...+180	+5...+90 <sup>4</sup>

Tab. 3: Temperature ranges

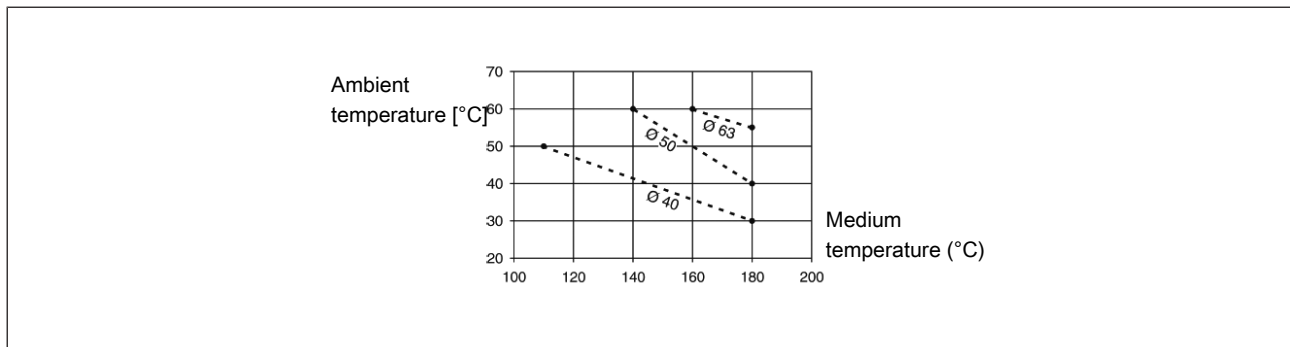

Fig. 5: Temperature range of maximum medium and ambient temperature for PA actuators

### 6.4.2 Pressure ranges

Actuator material	Actuator size [mm]	Max. Pilot pressure [bar]
PA	ø40...ø80	10
	ø125	7
PPS	ø40...ø80	10
	ø125	7

Tab. 4: Maximum pilot pressure

### 6.4.3 Minimum pilot pressure values

Minimum control pressure when flow direction below seat

(Medium flow against valve closing direction)

The required minimum pilot pressure  $P_{min}$  for control function A is:

Actuator size [mm]	ø40	ø50	ø63	ø80	ø100	ø125	ø125 DN80
$P_{min}$ [bar]	4.0	3.9	4.5	5.0	4.4	3.2	4.1

Tab. 5: Minimum pilot pressure SFA

<sup>3</sup>When using a pilot valve the max. ambient temperature is +55 °C.

<sup>4</sup>briefly up to a max. of 140°C



**Required minimum control pressure depending on the medium pressure**

In the following graphs the required minimum control pressure is shown for the respective control function depending on the medium pressure.

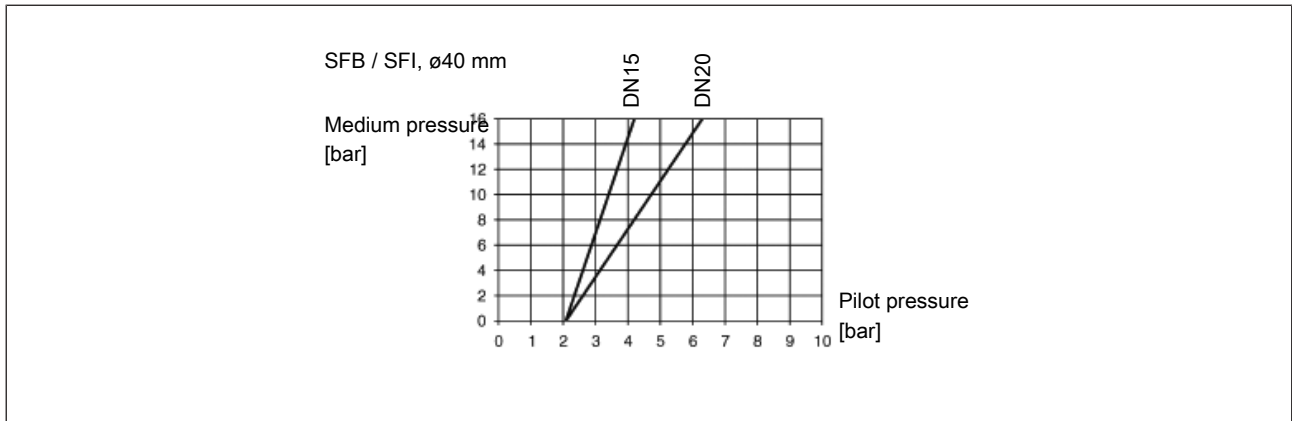

Fig. 6: Actuator ø40 mm, control function B und I, flow direction below the seat

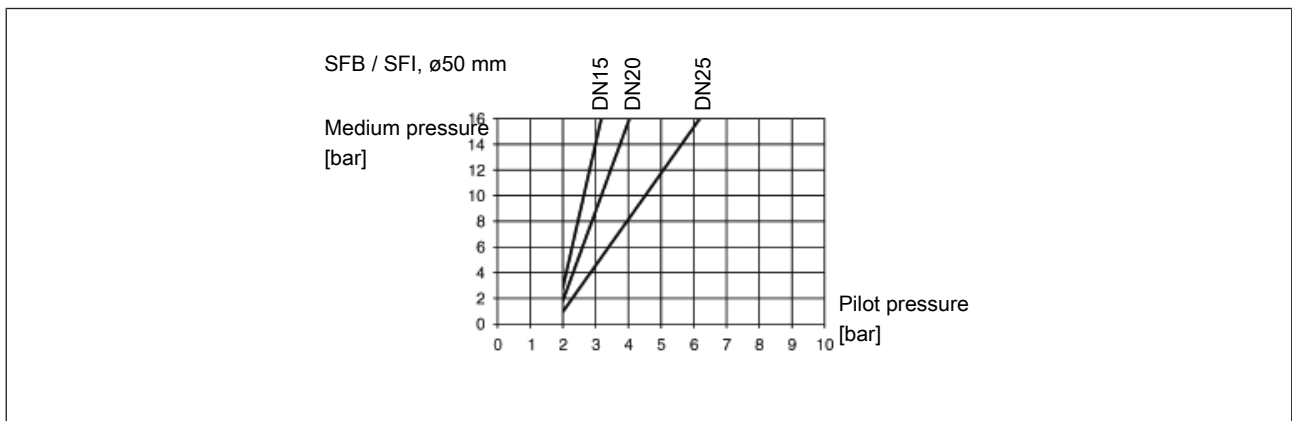

Fig. 7: Actuator ø50 mm, control function B und I, flow direction below the seat

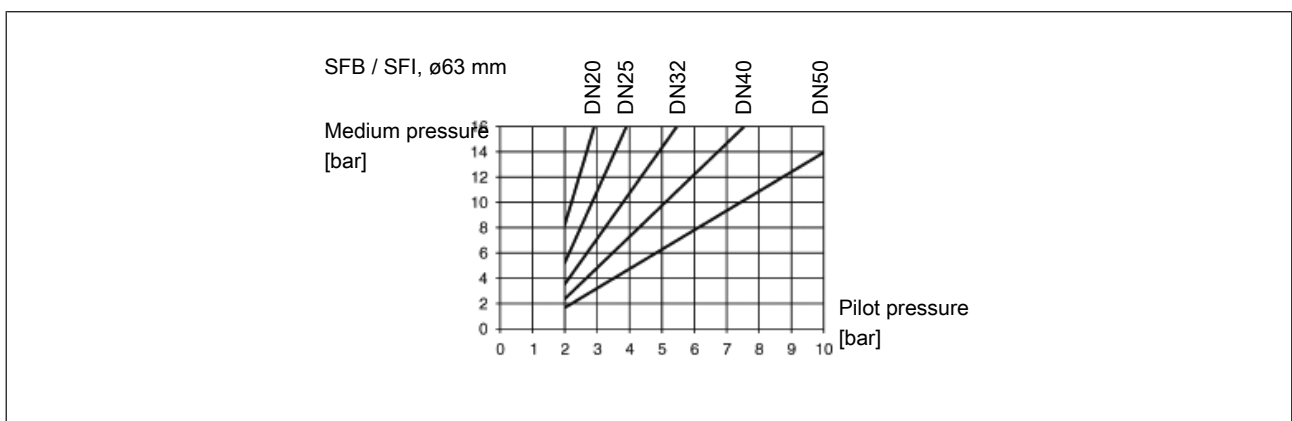

Fig. 8: Actuator ø63 mm, control function B und I, flow direction below the seat

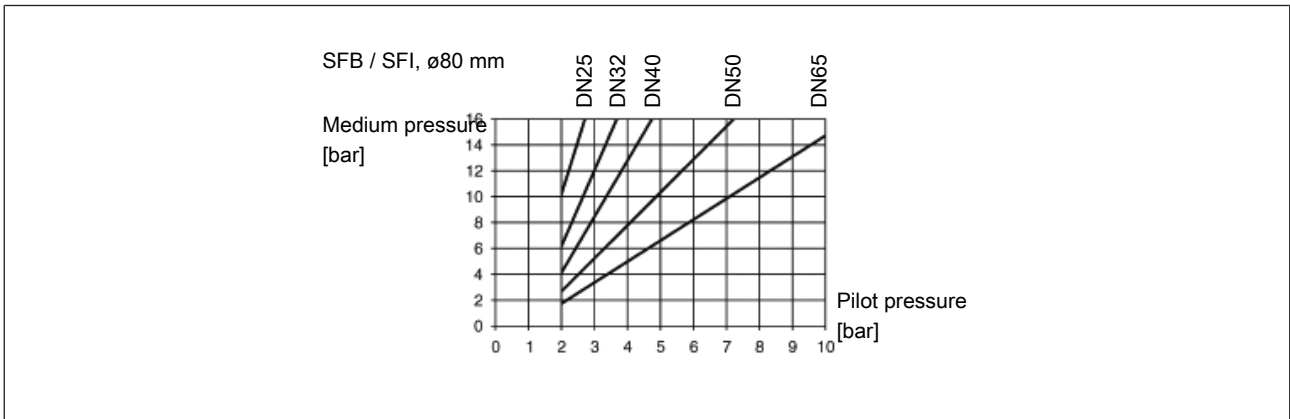

Fig. 9: Actuator ø80 mm, control function B und I, flow direction below the seat

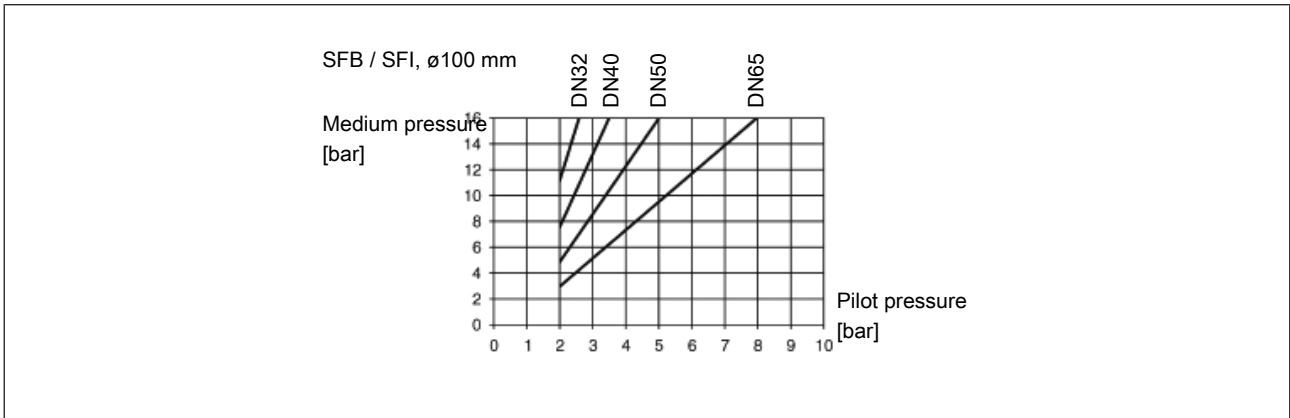

Fig. 10: Actuator ø100 mm, control function B und I, flow direction below the seat

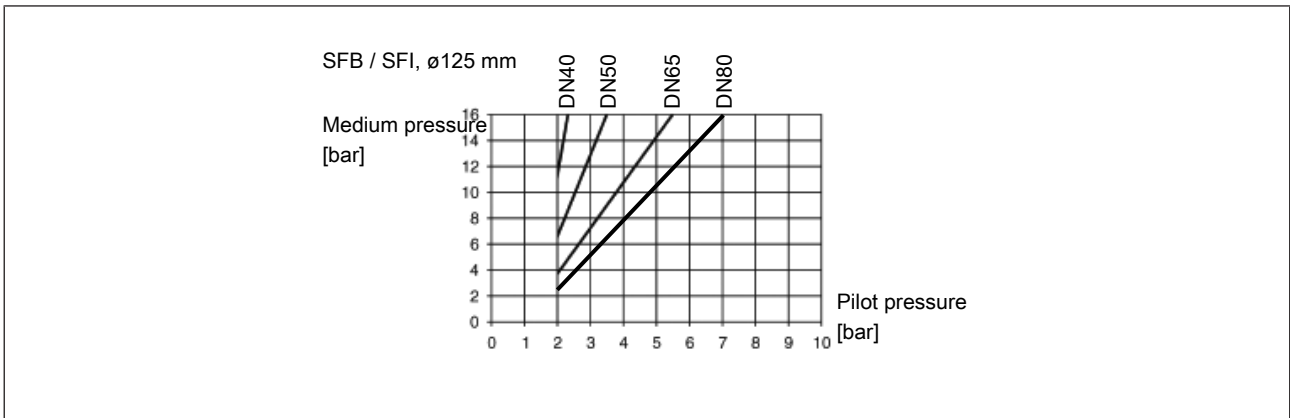

Fig. 11: Actuator ø125 mm, control function B und I, flow direction below the seat

**Minimum control pressure when flow direction above the seat**  
(Medium flow in valve closing direction)

**Required minimum control pressure depending on the medium pressure**

In the following graphs the required minimum control pressure is shown for the respective control function depending on the medium pressure.

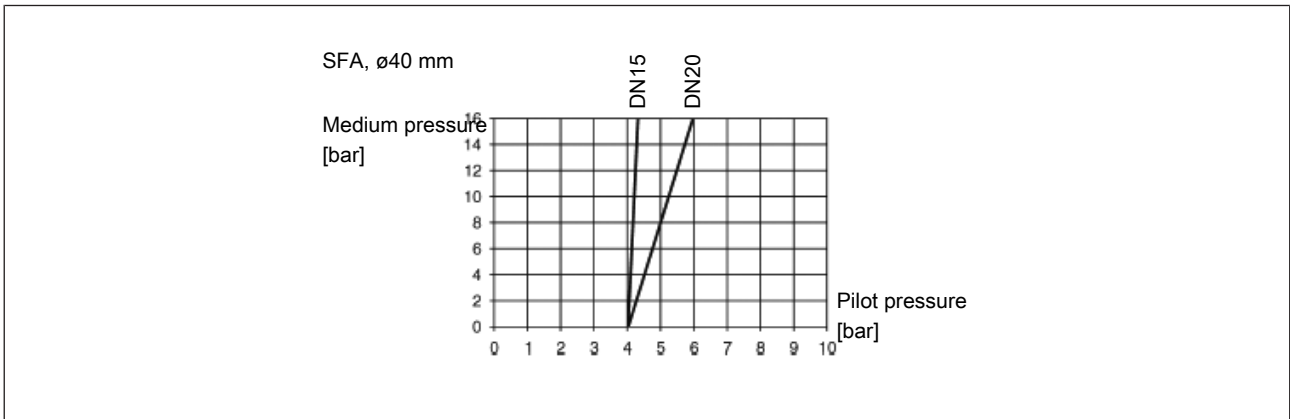

Fig. 12: Actuator ø40 mm, control function A, flow direction above the seat

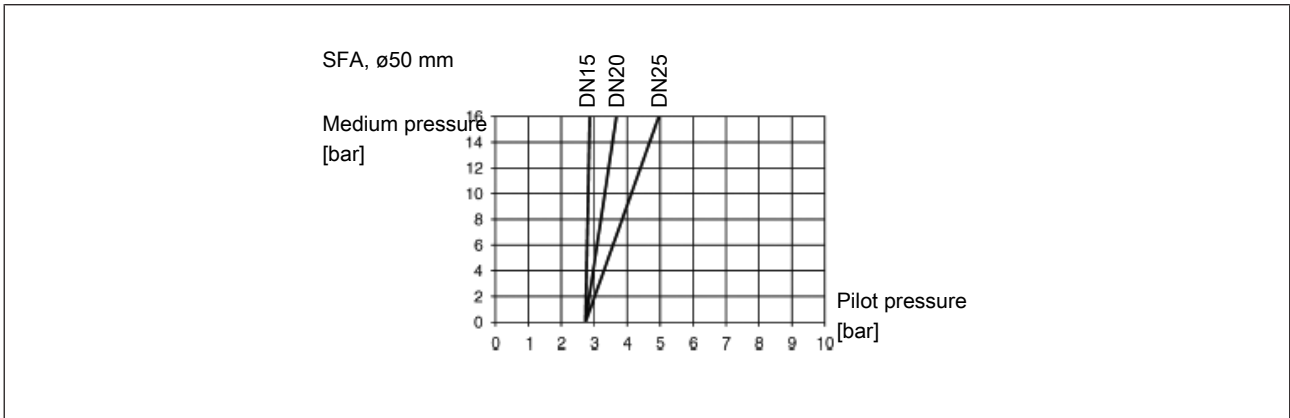

Fig. 13: Actuator ø50 mm, control function A, flow direction above the seat

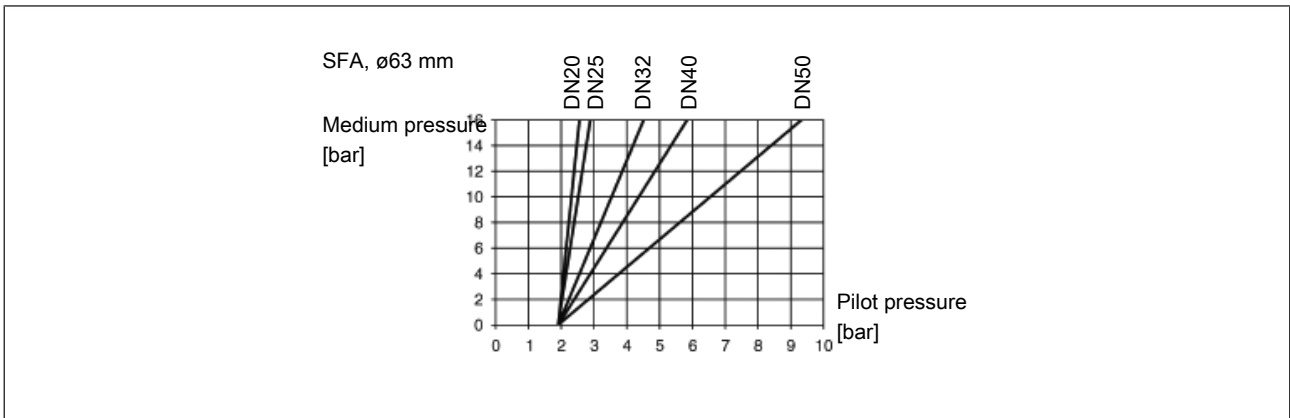

Fig. 14: Actuator ø63 mm, control function A, flow direction above the seat

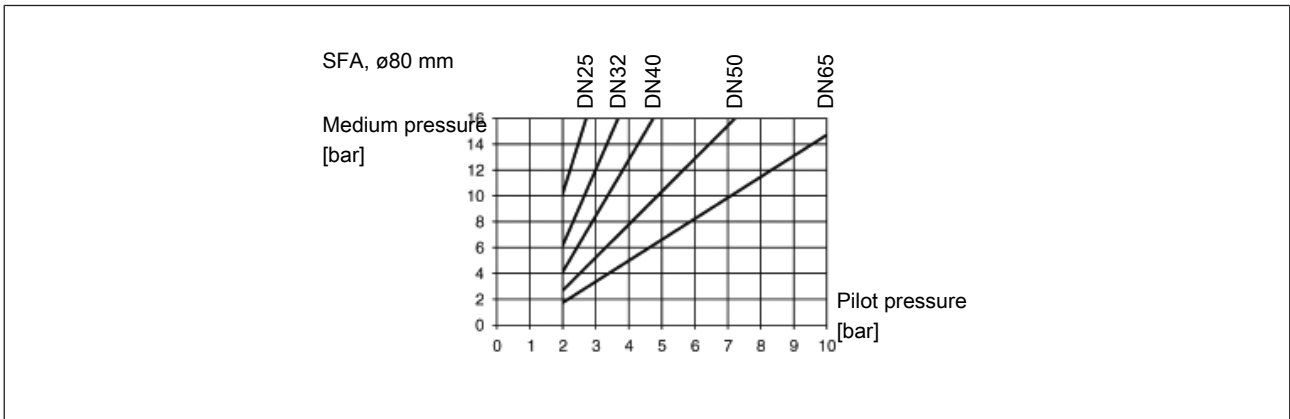

Fig. 15: Actuator ø80 mm, control function A, flow direction above the seat

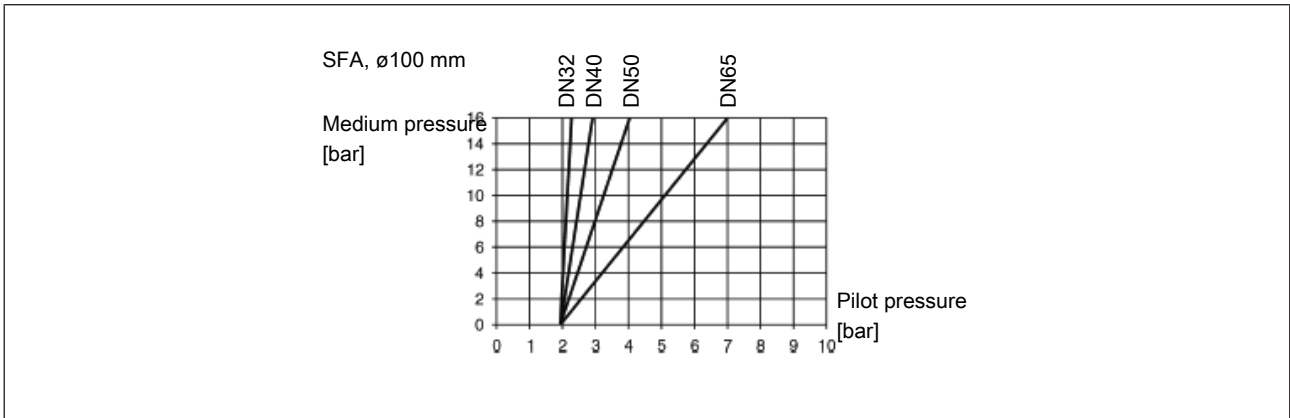

Fig. 16: Actuator ø100 mm, control function A, flow direction above the seat

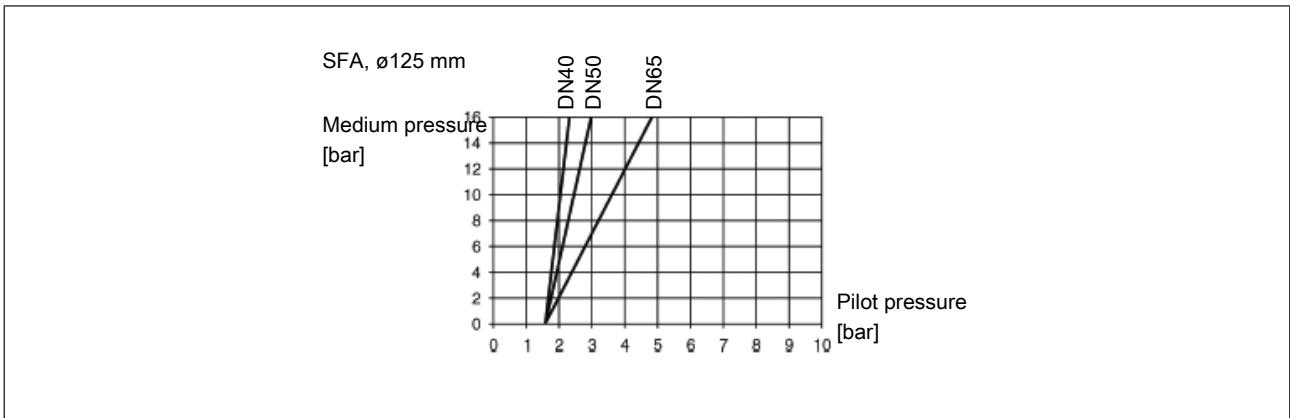

Fig. 17: Actuator ø125 mm, control function A, flow direction above the seat

## 6.5 Mechanical data

Actuator size	See type label
Installation position	any, preferably actuator face up

### Materials

Threaded connection	Red bronze Stainless steel 316L
---------------------	------------------------------------

Welded connection and clamp connection	Stainless steel 316L
actuator	PA or PPS
Seal	PTFE (NBR, FKM, EPDM on request)
Packing gland (with silicone grease) Stainless steel valve body	PTFE V-rings with spring compensation
Packing gland (with silicone grease) Red bronze valve body	PTFE and FKM V-rings with spring compensation

### Ports

Threaded connection	G $\frac{1}{2}$ ...G2 $\frac{1}{2}$ (VA G3) (NPT on request)
welded connection	in accordance with EN 1127, DIN 11850 R2
Clamp connection	in accordance with ISO 2852, ASME BPE, BS 4825
Pilot air port	Push-in connector 6/4 mm or threaded connection 1/4" More on request

## 7 INSTALLATION

### 7.1 Safety instructions installation

#### **DANGER!**

Risk of injury from high pressure and discharge of medium.

- ▶ Before working on the device or system, switch off the pressure. Vent or drain lines.

#### **WARNING!**

Risk of injury due to improper installation.

- ▶ Only trained technicians may perform installations.
- ▶ Perform installations with suitable tools only.

#### **WARNING!**

Risk of injury due to unintentional activation of the system and uncontrolled restart.

- ▶ Secure plant to prevent unintentional activation..
- ▶ Ensure that the plant starts up in a controlled manner only.

#### **DANGER!**

For control function I: Danger due to the control pressure failing.

If the control pressure fails, the valve remains in an undefined position.

- ▶ For a controlled restart, pressurize the device with control pressure and then connect the medium.

#### **WARNING!**

Risk of injury due to moving parts.

- ▶ Do not reach into openings in the device.

#### **CAUTION!**

Risk of injury from heavy device.

During transportation or installation work, a heavy device may fall down and cause injuries.

- ▶ Transport, install and remove heavy device with the aid of a second person only.
- ▶ Use suitable tools.

#### **WARNING!**

Valve seat leaking when control pressure is too low or medium pressure is too high.

If control pressure is too low for control function B and control function I or medium pressure is too high, the valve seat may leak.

- ▶ Observe values for minimum control pressure and maximum medium pressure.

#### **DANGER!**

Risk of injury from rupturing lines and device when flow direction above the seat.

A pressure surge of liquid media may cause the lines and device to rupture.

- ▶ Do not use valves with flow direction above the seat for liquid media.

## 7.2 Preparatory work

- Observe flow direction on the type label.
- Remove soiling from pipelines.
- Ensure that pipelines are in alignment.

### 7.2.1 Attach dirt trap

Dirt trap for devices with approval according to DIN EN 161

According to DIN EN 161 "Automatic shut-off valves for gas burners and gas appliances", a dirt trap, which prevents the penetration of a 1 mm test pin, must be installed upstream of the valve.

- Attach dirt trap upstream of the valve.

## 7.3 Installing valve body

- Connect valve body to pipeline.
- Devices with welded connection: Weld valve body into pipeline. To do this, observe chapter "Installing devices with welded connection".

## 7.4 Installing devices with welded connection

### ATTENTION!

Damage to the actuator when welding the valve body into the pipeline.

- ▶ Before welding into the pipeline, remove the actuator.

### 7.4.1 Removing actuator from the valve body for devices without control unit

- Clamp valve body into a holding device.

Devices with collet

### ATTENTION!

Damage to the valve seat seal or seat contour.

- ▶ When removing the actuator, the valve must be in the open position.

- For control function A pressurise the pilot air port 1 with compressed air (5 bar). Valve opens.
- Place a suitable open-end wrench on the wrench flat of the body connection.
- Unscrew actuator from the valve body.

Devices without collet

- For control function A: Install control unit. To do this, follow the operating instructions for the control unit.

### ATTENTION!

Damage to the valve seat seal or seat contour.

- ▶ When removing the actuator, the valve must be in the open position.

- For control function A pressurise the pilot air port 1 with compressed air (5 bar). Valve opens.
- For control function A with pilot valve: Manually switch device with pilot valve. To do this, follow the operating instructions for the control unit. Valve opens.
- Place a suitable open-end wrench on the wrench flat of the body connection.
- Unscrew actuator from the valve body.

### 7.4.2 Removing actuator from the valve body for devices with installed control unit

- Clamp valve body into a holding device.

#### ATTENTION!

**Damage to the valve seat seal or seat contour.**

- ▶ When removing the actuator, the valve must be in the open position.

- For control function A pressurise the pilot air port 1 with compressed air (5 bar). Valve opens.
- For control function A with pilot valve: Manually switch device with pilot valve. To do this, follow the operating instructions for the control unit. Valve opens.
- Place a suitable open-end wrench on the wrench flat of the body connection.
- Unscrew actuator from the valve body.

### 7.4.3 Installing actuator on valve body

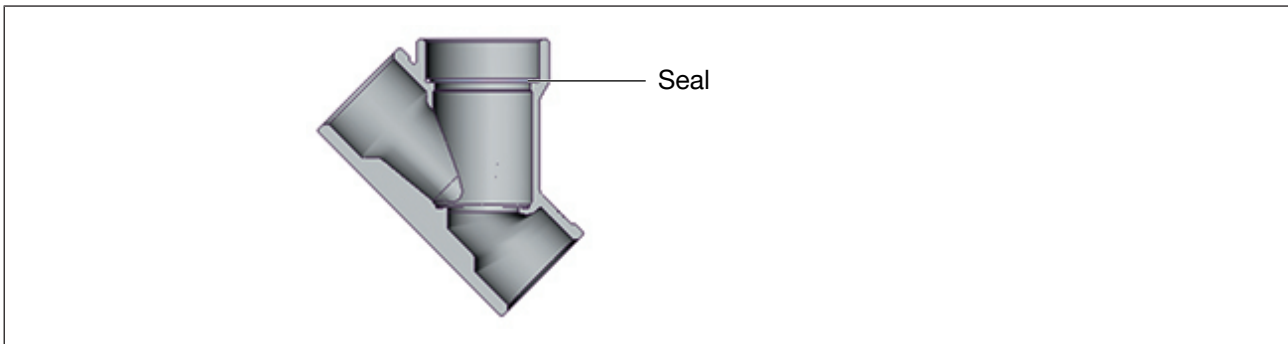

Fig. 18: Seal

- Check seal and replace if required.

#### **!** DANGER!

**Danger due to lubricant.**

Lubricant may contaminate the medium. There is a risk of explosion in oxygen applications.

- ▶ For specific applications use only approved lubricants (e.g. for oxygen applications or analysis applications).

- Before re-installation, grease the thread of the body connection (e.g. with Klüberpaste UH1 96-402 from Klüber).

#### ATTENTION!

**Damage to the valve seat seal or seat contour.**

- ▶ When installing the actuator, the valve must be in the open position.



→ Screw actuator into the valve body. Observe tightening torques of the following table.

Seat size	Tightening torque [Nm]
15	45 ±3
20	50 ±3
25	60 ±3
32	65 ±3
40	65 ±3
50	70 ±3
65	70 ±3
80	120 ±5

Tab. 6: Tightening torques valve body and body connection

## 7.5 Installing control unit



Description see chapter "Installation" in the operating instructions for the corresponding control unit.

## 7.6 Turning actuator

### 7.6.1 Turning the actuator, devices with hexagon nut



The following description applies only to devices with a hexagon head on the actuator.

For devices without a hexagon head on the actuator: in the operating instructions observe the chapter "Turning actuator, devices without a hexagon head".

The position of the ports can be steplessly aligned by turning the actuator through 360°.

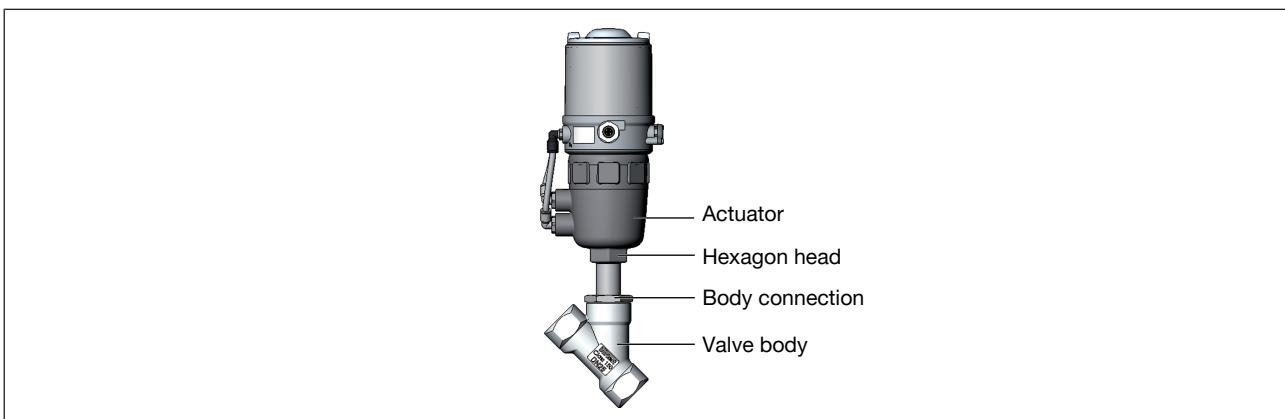

Fig. 19: Turn actuator (1)

→ Clamp valve body in a holding device (only for valves which have not yet been installed).

### ATTENTION!

Damage to the seat seal or seat contour.

- ▶ When turning the actuator, the valve must be in the open position.

- For control function A und I<sup>5</sup>:  
pressurise lower pilot air port with compressed air.
- Counter with a suitable open-end wrench on the wrench flat of the body connection.
- Place a suitable open-end wrench on the hexagon head of the actuator.

**! DANGER!**

**Risk of injury from high pressure and discharge of medium.**

If the direction of rotation is wrong, the body connection may become detached.

- ▶ Only turn the actuator in the prescribed direction.

- Move the actuator into the required position by turning it counterclockwise (seen from below).

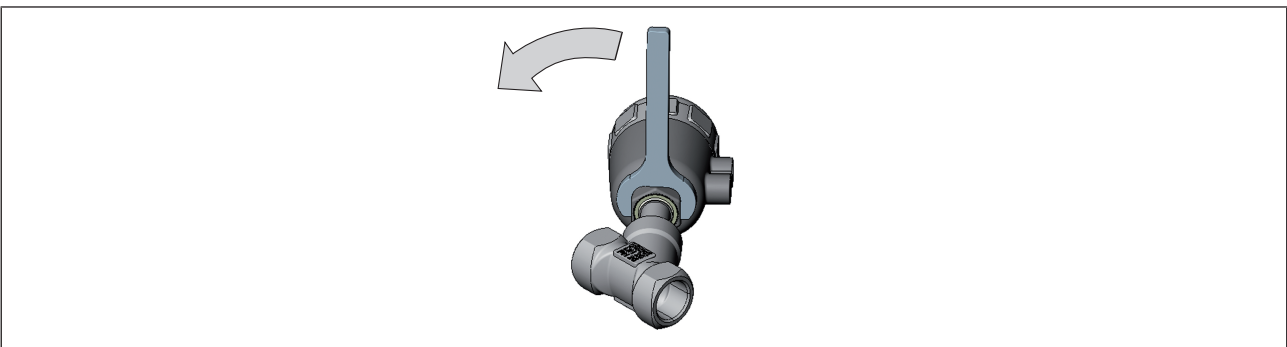

Fig. 20: Turn actuator (2)

## 7.7 Connecting device pneumatically

**! DANGER!**

**For control function I: Danger due to the control pressure failing.**

If the control pressure fails, the valve remains in an undefined position.

- ▶ For a controlled restart, pressurize the device with control pressure and then connect the medium.

**! DANGER!**

**Risk of injury due to connection of unsuitable hoses.**

- ▶ Use only hoses which can withstand the pressure and temperature of the medium.
- ▶ Observe technical data of the hose manufacturer.

### 7.7.1 Connecting control medium



The position of the ports can be steplessly aligned by turning the actuator through 360°. The procedure is described in the chapter "Turning actuator [▶ 25]".

**Control function A:**

Connect control medium to pilot air port at the bottom.

**Control function B:**

Connect control medium to pilot air port at the top.

**Control function I:**

<sup>5</sup> If variant available

Connect control medium to pilot air port at the top and bottom.

Pressure on top connector closes the valve.

Pressure on bottom connector opens the valve.

Control function	Pilot air port		
	Top	Bottom	
A		X	 <p>Pilot air connection Top Bottom</p>
B	X		
I	X	X	
	Closes	Opens	
	valve		

Tab. 7: Pilot air port



When operating in an aggressive environment, divert free pneumatic ports into a neutral atmosphere using a pneumatic hose.

Pilot air hose:

Pilot air hoses of sizes G $\frac{1}{4}$ " or G $\frac{1}{8}$ " (actuator  $\varnothing$ 40 mm) can be used.

## 8 START-UP



### **DANGER!**

For control function I: Danger due to the control pressure failing.

If the control pressure fails, the valve remains in an undefined position.

- ▶ For a controlled restart, pressurize the device with control pressure and then connect the medium.



### **WARNING!**

Risk of injury from high pressure or hot medium.

Excessively high pressure or temperatures may damage the device and cause leaks.

- ▶ Observe values for pressure and medium temperature indicated on the type label.



In the case of devices with control unit, observe start-up in the operating instructions for the corresponding control unit.

→ Adjust pilot pressure in accordance with information on type label and in technical data.

## 9 DEINSTALLATION



### **DANGER!**

Risk of injury from high pressure and discharge of medium.

▶ Before working on the device or system, switch off the pressure. Vent or drain lines.

→ Loosen pneumatic connection.

→ Disassemble the device.

## 10 SERVICING

### 10.1 Safety instructions maintenance

#### **DANGER!**

Risk of injury from high pressure and discharge of medium.

- ▶ Before working on the device or system, switch off the pressure. Vent or drain lines.

#### **DANGER!**

For control function I: Danger due to the control pressure failing.

If the control pressure fails, the valve remains in an undefined position.

- ▶ For a controlled restart, pressurize the device with control pressure and then connect the medium.

#### **DANGER!**

Risk of injury due to electric shock.

- ▶ Before working on the device or system, switch off the power supply. Secure against reactivation.
- ▶ Observe the applicable accident prevention and safety regulations for electrical devices.

#### **WARNING!**

Risk of injury due to unintentional activation of the system and uncontrolled restart.

- ▶ Secure plant to prevent unintentional activation..
- ▶ Ensure that the plant starts up in a controlled manner only.

#### **WARNING!**

Risk of injury due to moving parts.

- ▶ Do not reach into openings in the device.

#### **DANGER!**

Risk of injury due to improper maintenance.

- ▶ Only trained technicians may perform maintenance work.
- ▶ Perform maintenance work using suitable tools only.

### 10.2 Maintenance work

The maintenance work is described in the separate service instructions. These instructions can be found on our homepage at [www.buerkert.de](http://www.buerkert.de).

#### 10.2.1 Actuator

When used in accordance with these operating instructions, the actuator is maintenance-free.

#### 10.2.2 Wearing parts

The following parts are subject to natural wear:

- Seal

- Swivel plate
- If leaks occur, replace the respective wearing part.

### 10.2.3 Visual inspection

According to the usage conditions, perform regular visual inspections:

- Check medium ports for tightness.
- Check relief bore on the pipe for leaks.

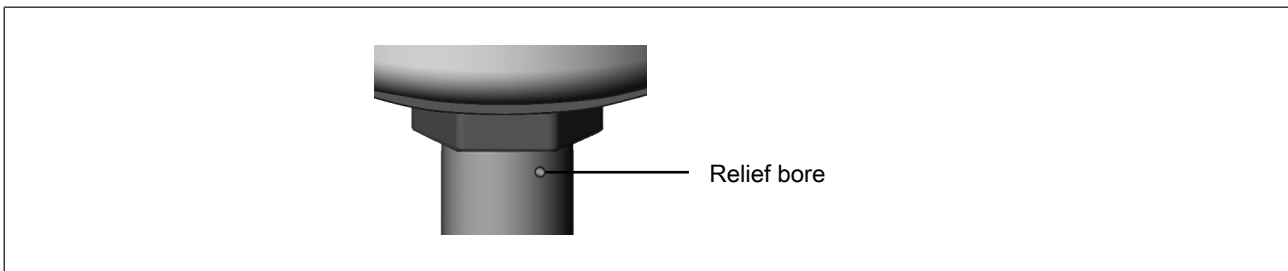

Fig. 21: Relief bore

### 10.2.4 Cleaning

Commercially available cleaning agents can be used to clean the outside.

#### **ATTENTION!**

**Avoid causing damage with cleaning agents.**

- ▶ Before cleaning, check that the cleaning agents are compatible with body materials and seals.

## 11 FAULTS

Fault	Cause	Elimination	
Actuator does not switch	Pilot air port inter- changed	CFA	Connect pilot air port at bottom
		CFB	Connect pilot air port at top
		CFI	Pilot air port at bottom: Open, pilot air port at top: Closing
	Pilot pressure too low	Observe pressure specifications on the type label	
	Medium pressure too high		
	Flow direction inter- changed	Observe direction of arrow on the type label	
Valve is not tight	Dirt between seal and valve seat	Install dirt trap	
	Valve seat seal worn	Install new swivel plate	
	Flow direction inter- changed	Observe direction of arrow on the type label	
	Medium pressure too high	Observe pressure specifications on the type label	
	Pilot pressure too low		
Valve is leaking on the relief bore	Packing gland worn	Replace packing gland or actuator	



## 12 REPLACEMENT PARTS, ACCESSORIES

### CAUTION!

Risk of injury and/or damage due to the use of incorrect parts.

Incorrect accessories and unsuitable spare parts may cause injuries and damage the device and its environment.

- ▶ Use original accessories and original spare parts from Bürkert only.

### 12.1 Installation tools

Installation wrench for packing gland (series-production status up to January 2013)		
Spindle [mm]	Seat size	Order No.
ø10	15...40	665700
ø14	32...65	665701

Tab. 8: Installation wrench

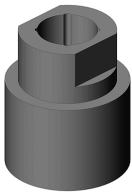
Modified socket wrench for packing gland (series-production status as of January 2013)				
	Spindle [mm]	Seat size	Width across flats	Order No.
	ø10	15...50 <sup>6</sup>	19	683221
	ø14	32...80	21	683223

Tab. 9: Modified socket wrench

Special wrench for turning the actuator (series-production status up to end of 2011)	
Order No.	665702

Tab. 10: Special wrench



If you have any questions, contact your Bürkert sales department.

### 12.2 Replacement part set

The following spare part sets are available for the device:

- Valve set consists of swivel plate with PTFE seal, pin and seal.
- Seal set for actuator consists of the seal and wearing parts of the actuator.

<sup>6</sup>As of series-production status January 2017 also for seat size 50

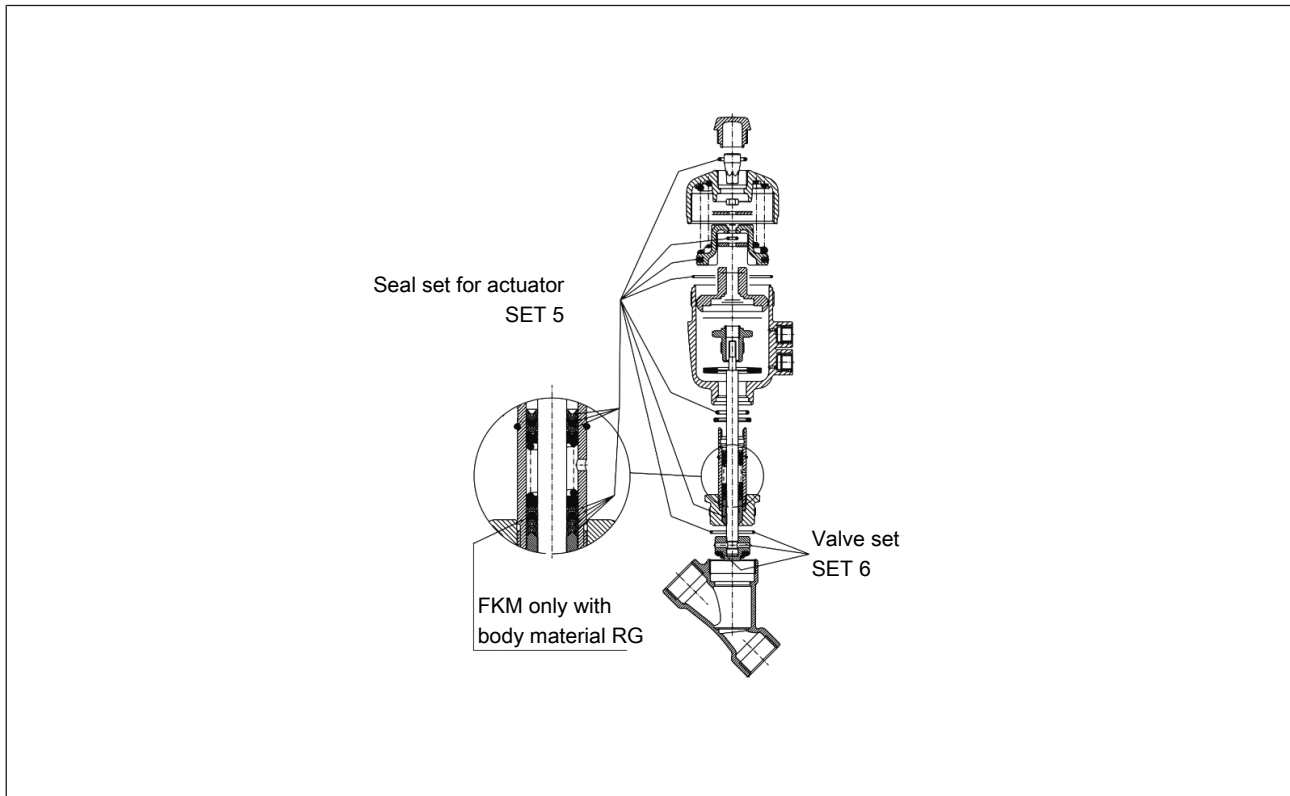

Fig. 22: Spare parts for angle seat valve

## 12.3 Spare parts for seal set for SET 5 actuator

### PA actuator

Actuator size	Matching valve sizes	Order no. (Red bronze valve body)	Order no. (Stainless steel valve body)
C (ø40) <sup>7</sup>	DN15/20/25	233587	233587
C (ø40)	DN15/20/25	288011	288011
D (ø50)	DN15/20/25	233588	233588
E (ø63)	DN25...50	233591	233591
F (ø80)	DN25...65	233593	233593
G (ø100)	DN32...65	233594	233594
H (ø125)	DN40...65	233596	233596
H (ø125)	DN80	-	276132

Tab. 11: SET 5; PA actuator

## PPS actuator

Actuator size	Matching valve sizes	Order no. (Red bronze valve body)	Order no. (Stainless steel valve body)
C (ø40) <sup>8</sup>	DN15/20/25	233581	233581
C (ø40)	DN15/20/25	288013	288013
D (ø50)	DN15/20/25	233582	233582
E (ø63)	DN25...50	233583	233583
F (ø80)	DN25...65	233584	233584
G (ø100)	DN32...65	233585	233585
H (ø125)	DN40...65	233586	233586
H (ø125)	DN80	-	276130

Tab. 12: SET 5; PPS actuator

## 12.4 Spare parts for valve set SET 6

## RG body

DN	Order no. (PTFE seal)	Order no. (FKM seal)
15	010984	011065
20	010986	011070
25 <sup>9</sup>	010988	011085
25 <sup>10</sup>	159635	-
32	011044	011088
40	011046	011107
50	233819	233821
65	233820	233822

Tab. 13: SET 6; Red bronze valve body

## VA body

DN	Order no. (PTFE seal)	Order no. (FKM seal)
15	011134	011234
20	011171	011253
25 <sup>11</sup>	011202	011259

<sup>8</sup> Actuator cover without transparent cap<sup>9</sup> Actuator size ø50<sup>10</sup> Actuator size ø63<sup>11</sup> Actuator size ø50

DN	Order no. (PTFE seal)	Order no. (FKM seal)
25 <sup>12</sup>	160737	168816
32	011208	011262
40	011209	011267
50	233813	233817
65	233815	233818
80	350831	-

Tab. 14: SET 6; Stainless steel valve body

## 13 TRANSPORTATION, STORAGE, DISPOSAL

### ATTENTION!

Damage in transit due to inadequately protected devices.

- ▶ Protect the device against moisture and dirt in shock-resistant packaging during transportation.
- ▶ Observe permitted storage temperature.

### ATTENTION!

Incorrect storage may damage the device.

- ▶ Store the device in a dry and dust-free location.
- ▶ Storage temperature: -20 to +65 °C

### ATTENTION!

Damage to the environment caused by device components contaminated with media.

- ▶ Dispose of the device and packaging in an environmentally friendly manner.
- ▶ Observe applicable disposal and environmental regulations.



Observe national regulations on the disposal of waste.