

# PVC SLIDING GATE VALVE

## Features

- Unrestricted flow
- Quick opening / closing
- Simple and trouble-free operation
- Solvent cement socket ends
- Available in 40mm – 150mm

## Applications

- Tank drain valve
- Effluent truck valve
- Quick shutoff in low pressure or vacuum lines
- Low pressure industrial or agricultural applications

## Materials

- Body – PVC
- Shaft – Stainless Steel
- Paddle – Polypropylene
- Handle – Plastic
- Seals - Santoprene

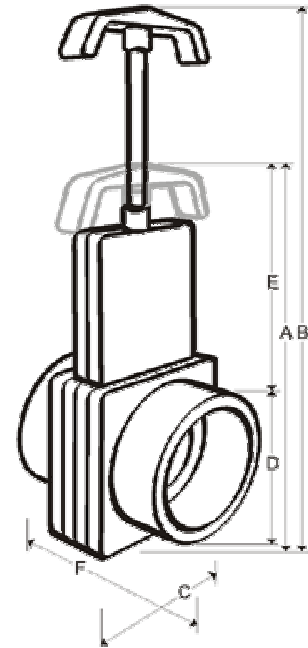

Dimensions						
Size	A	B	C	D	E	F
40mm	165	219	73	60	100	86
50mm	190	260	83	70	114	89
80mm	235	330	111	100	132	114
100mm	337	457	168	127	189	132
150mm	568	790	279	185	337	282

“B” Dimensions are height of valve in fully open position

## Pressure Rating

- 40mm - 300 kpa
- 50mm - 275 kpa
- 80mm - 200 kpa
- 100mm - 150 kpa
- 150mm - 75 kpa

**Maximum Temperature 40° C**

## Ordering Information

- **GVS40** - 40mm Slip
- **GVS50** - 50mm Slip
- **GVS80** - 80mm Slip
- **GVS100** - 100mm Slip