



Pro-Matic pneumatic actuators



$n_1 \times O_1$

$\varnothing E (H_1)$

$N_1 (PCD)$

$N_2 (PCD)$

Pro-Matic designs, manufactures and markets quarter turn pneumatic actuators for all types of quarter turn valves.

All our products meet with very high demands and safety and long life service and a reliable performance in all major valve applications. Pro-Matic pneumatic actuators are manufactured in 16 different sizes, in both single and double acting using The idea behind Pro-Matic pneumatic actuators is to built pneumatic actuators according ISO standard quality assurance, only machined on CNC machines to achieve the highest engineering standard. All actuators are tested before leaving our factory on our state of the art testing rig.

Pro-Matic goal is to offer not only competitively prices quality pneumatic actuators but as well to assist our customers with service and know-how. This also includes Adaptation solutions, Switch boxes, Solenoid valves and Manual override gearboxes (MO-D) to meet customer requirements.

The products and services of Pro-Matic will continuously be adapted to the requirements of the customers and the market and shall always be associated with quality.



Contents

Construction _____	3
Sizing _____	4
Parts and Material _____	12
Technical info _____	13
Dimensional drawing _____	14
Accessories _____	15

Key Features

- Direction of rotation can be optionally changed from clockwise (CW) to anti clockwise (CCW)
- End-position sensor and limit switchbox can be mounted directly to the actuator
- Suitable for manual on-site use, as well as automatic operation
- Port pattern to Namur VDI/VDE 3845 for mounting solenoid valves.
- Highly corrosion resistant

1. Actuator body

According to the different requirements, the extruded aluminum alloy ASTM6005 body can be treated with hard anodized, powder polyester painted (different colors is available) PTFE or Nickel plated.

2. End Caps.

Die-casting aluminum powder polyester painted in different colors, PTFE or Nickel plated.

3. Pistons.

The twin rack pistons are made from Die-casting aluminum treated with Hard anodized or made from Cast steel with galvanization. A symmetric mounting position, long cycle life and fast Operation, reversing rotation by simply inverting the pistons.

4. Indicator.

The position indicator according NAMUR standard is convenient for mounting accessories such as Limit Switch Box, Position and so on.

5. Pinion.

The pinion is high-precision and integrative, made from nickel-alloy steel, full conform to the latest standards of ISO5211, DIN3337 and NAMUR. The dimensions can be customized and a stainless steel pinion is available.

6. Travel adjustment.

The two independent external travel stop adjustment bolts can be adjusted $\pm 5^\circ$ at both open and closed directions easily and precisely.

7. High performance springs.

Pre-loaded, coated springs are made from the high quality material for resistant to corrosion and longer service life, which can be demounted safely and conveniently to satisfy different requirements of torque by changing the quantity of springs.

8. O-rings.

NBR O-rings provide trouble-free operation at standard temperature ranges. For high and low temperature applications Viton or Silicone.

9. Bearings & Guides.

Bearings and guides are made from low friction, long-life compound material to avoid the direct contact between metals. The maintenance and replacement is easy and convenient.

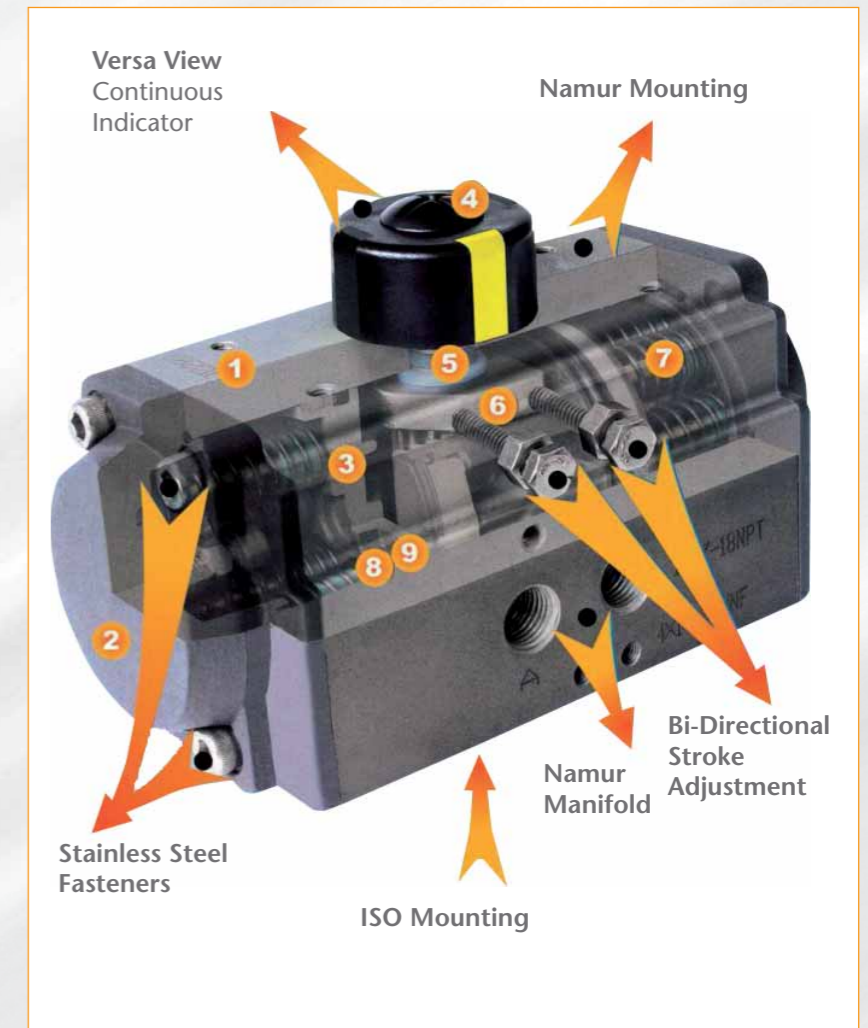

For the sizing examples in this website we will use a rack- and pinion actuator to explain how to size double-acting and single acting quarter turn actuators.

Standard operating conditions for our standard actuators

1. **Operating media**
Dry or lubricated air, or the non-corrosive gases.
The maximum particle diameter must be less than 30µm.
2. **Air supply pressure**
The minimum supply pressure is 2.5 Bar.
The maximum supply pressure is 8 Bar.
3. **Operating temperature**
Standard temperature range: -20°C - +80°C
4. **Travel adjustment**
Standard travel adjustment: +/-5° for the rotation at 0° and 90°
5. **Application**
Standard application: Either indoor or outdoor.

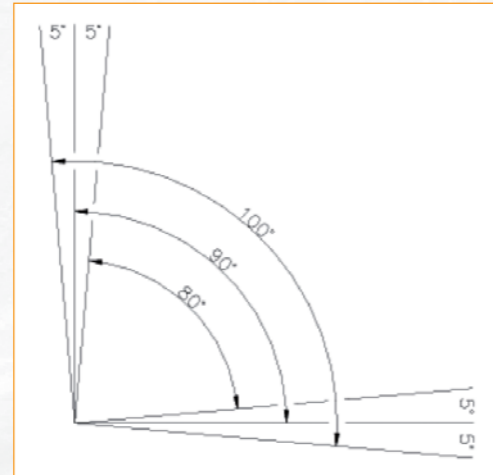

Double acting quarter turn actuators

General operating principle of a double acting actuator

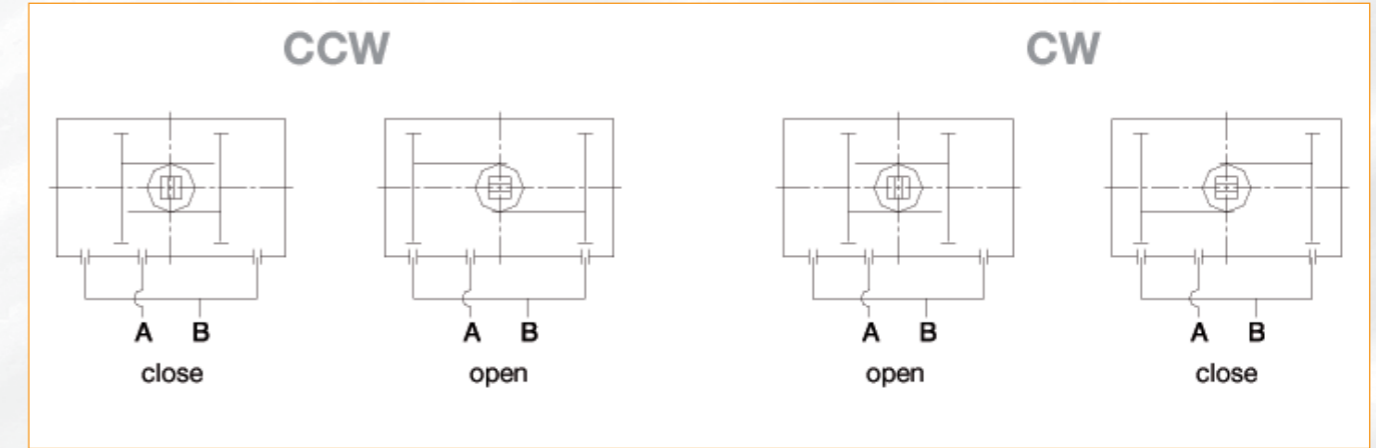

Fig. 3

Air to port A forces the pistons outwards, causing the pinion to turn clockwise while the air is being exhausted from port B.

Air to port A forces the pistons outwards causing pinion to turn counterclockwise while the air is being exhausted from port B.

Air to port B forces the pistons inwards, causing the pinion to turn counterclockwise while the air is being exhausted from port A.

Air to port B forces the pistons inwards, causing the pinion to turn clockwise while the air is exhausted from port A

Output torque of double acting actuators.

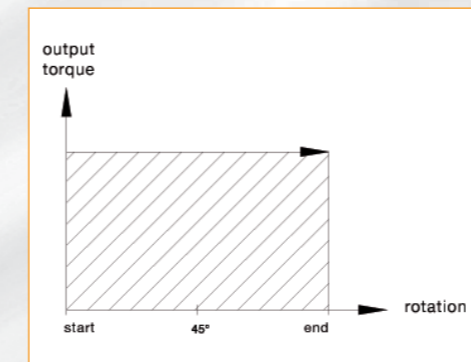

Fig. 4

Sizing a double acting actuator

To size a double acting actuator there are different parameters important to be known:

Breakaway torque of the process valve.

The torque required to facilitate reliable opening of the valve's shut-off device (disk in a butterfly valve, ball in a ball valve...) under the specified operating conditions (medium, temperature, inline pressure, etc)

Compressed air supply.

The minimum compressed air pressure available at all time at the valve to be sized forms the basis for sizing (worst-case analysis).

Process valve type.

What type of valve (butterfly valve, ball valve, etc) is being used?

The main operating conditions must be known before the breakaway torque can be specified by the valve manufacturer or correctly derived from existing tables.

- Medium
- Temperature, concentration, viscosity of the medium.
- Gas or liquid, lubricating or non-lubricating.
- Presence of particles that form deposits or caking
- Differential pressure at the process valve.
- Required safety factor.

If no safety factor is specified, a factor of at least approx. 1.25 (25% safety) should be taken into account when sizing the quarter turn actuator.

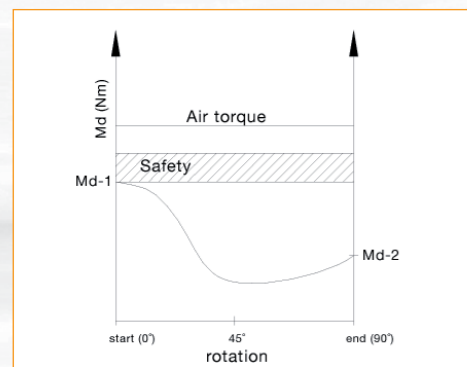

0° = Valve closed
 90° = Valve open
 Md1 = Breakaway torque
 Md2 = Closing torque

Sizing Example:

Data given:

1. Air pressure: 6 bar
2. Breakaway torque: 100 Nm
3. Safety factor: 25%

This gives a minimum torque of 125Nm for the quarter turn actuator. The Torque tables for double acting quarter turn actuators propose the actuator with the designation PM-110-DA. This actuator has a torque of 135,4Nm at compressed air pressure of 6 bar.

Fig. 5 Relationship of the actuator to the butterfly valve torque curve.

This torque is constant across the entire swivel range (0° - 90°) thanks to the rack and pinion design and is therefore sufficient for the valve.

Output Torque (Nm) of Double Acting Actuators (PM ___ DA)										
Model	Air pressure supplied to actuator (Bar)									
	2,0 Bar	2,5 Bar	3,0 Bar	4,0 Bar	4,5 Bar	5,0 Bar	5,5 Bar	6,0 Bar	7,0 Bar	8,0 Bar
PM-12-DA	4,8	6,0	7,2	9,6	10,8	12,0	13,2	14,4	16,8	19,2
PM-20-DA	8,0	10,0	12,0	16,0	18,0	20,0	21,9	23,9	27,9	31,9
PM-35-DA	14,6	18,2	21,9	29,2	32,8	36,5	40,1	43,8	51,1	58,4
PM-50-DA	20,1	25,1	30,1	40,1	45,1	50,2	55,2	60,2	70,2	80,3
PM-75-DA	31,4	39,2	47,0	62,7	70,5	78,4	86,2	94,1	109,7	125,4
PM-110-DA	45,1	56,4	67,7	90,3	101,6	112,9	124,1	135,4	158,0	180,6
PM-160-DA	66,1	82,7	99,2	132,2	148,8	165,3	181,1	198,4	231,4	264,5
PM-255-DA	100,3	125,4	150,5	200,6	225,7	250,8	275,9	301,0	351,1	401,3
PM-435-DA	171,0	213,8	256,5	342,0	384,8	427,5	470,3	513,0	598,5	684,0
PM-665-DA	266,0	332,5	399,0	532,0	598,5	665,0	731,5	798,0	931,0	1064,0
PM-1000-DA	425,6	532,0	638,4	851,2	957,6	1064,0	1170,4	1276,8	1489,6	1702,4
PM-1200-DA	532,0	665,0	798,0	1064,0	1197,0	1330,0	1463,0	1596,0	1862,0	2128,0
PM-1800-DA	769,5	961,9	1154,3	1539,0	1731,4	1923,8	2116,1	2308,5	2693,3	3078,0
PM-2700-DA	1169,6	1462,1	1754,5	2339,3	2631,7	2924,1	3216,5	3508,9	4093,7	4678,6
PM-3000-DA	1602,0	2002,5	2403,0	3205,0	3604,5	4006,0	4405,5	4807,0	5608,0	6409,0
PM-3500-DA	2399,0	2998,8	3598,0	4798,0	5397,8	5998,0	6597,3	7197,0	8397,0	9596,0
PM-4000-DA	3418,0	4272,5	5127,0	6837,0	7960,5	8546,0	9399,5	10255,0	11963,0	13672,0

rev.03 13-02-09

Single acting (spring return) quarter turn actuators

General operating principle of a single acting actuator

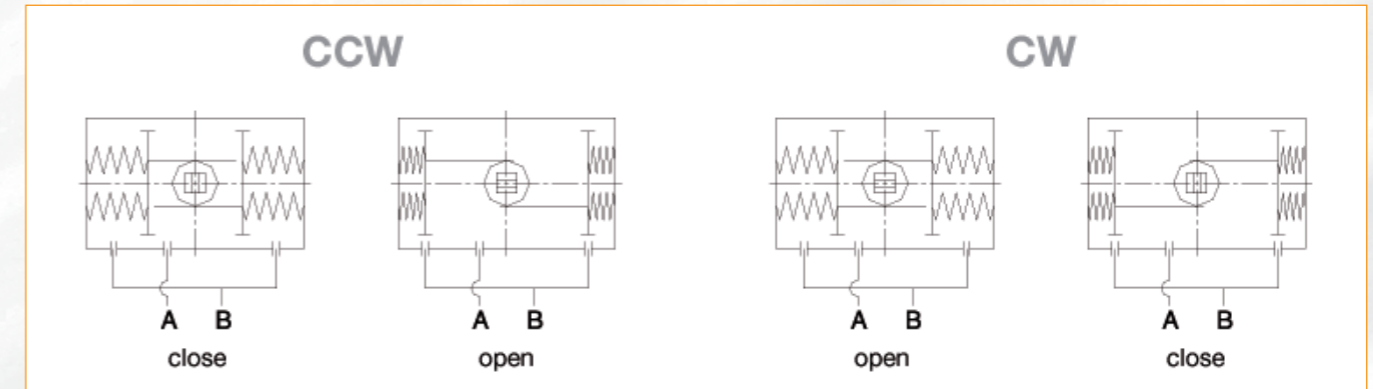

Fig. 6

Air to port A forces the pistons outwards causing the springs to compress.

The pinion turns counterclockwise while air is being exhausted from port B.

Loss of air pressure on port A, the stored energy in the springs forces the pistons inwards. The pinion turns clockwise while the air is exhausted from port A.

Air to port A forces the pistons outwards, causing the springs to compress.

The pinion turns clockwise while air is being exhausted from port B. Loss of air pressure on port A, the stored energy in the springs forces the pistons inwards.

The pinion turns counter clockwise while the air is being exhausted from port A.

Output torque of single acting actuators.

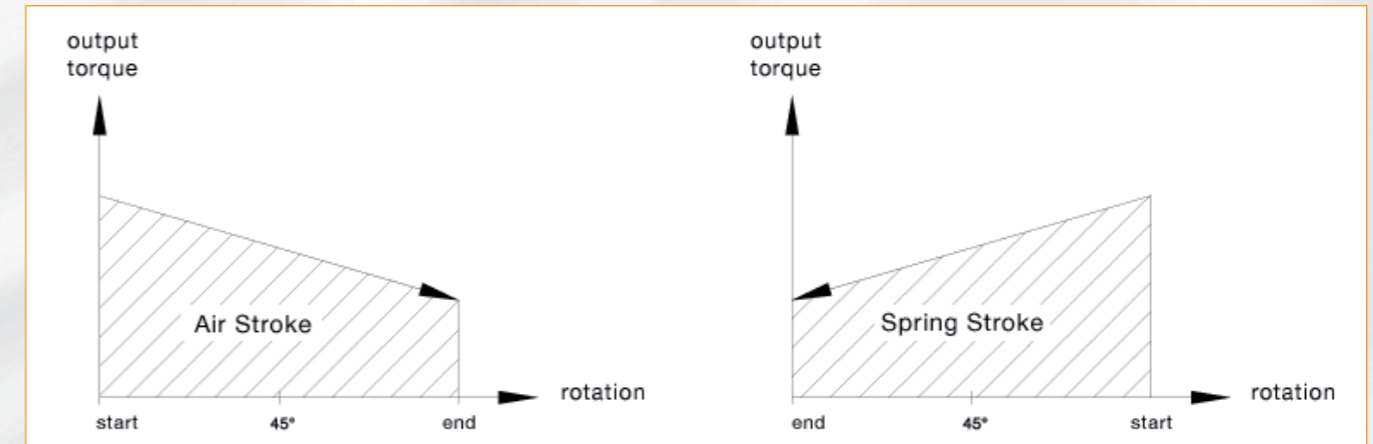

Fig. 7

Sizing a single acting actuator

The most frequent application: Closing with spring force

When the valve is closed, the springs in the actuators are pre tensioned. This means: A single-acting actuator will always have a lower maximum air torque than the identically sized double-acting actuator (same piston, same design)

When the process valve opens, the actuator works against the spring force. If the springs are compressed, the force in the springs increases and the opening force of the air decreases proportionally. This means that the actuator must overcome the torque generated by the spring force as well as the normal breakaway torque. The air torque decreases in accordance with the increasing spring force.

The most important criteria for the sizing of single acting quarter turn actuators are, with the exception of the valve's closing torque, the same as for double acting actuators.

- Breakaway torque of the process valve
- Closing torque of the process valve What torque is required to move the shut-off device (ball, valve ...) securely back into the seal?
- Compressed air supply
- Process valve type

As with double acting actuators, the main operating conditions must be known before the breakaway torque can be specified by the valve manufacturers or correctly derived from existing tables.

These conditions also apply for the closing torque. As the lubricating properties of the medium remain almost incalculable here, this is more difficult to determine.

For that reason, most process valve manufacturers do not specify a closing torque.

The Solution

The breakaway torque is used instead of the closing torque as it is always greater than the closing torque of a process valve. It can generally be assumed that the breakaway torque specified by the process valve manufacturer can be used without a safety factor. The suggested safety factor for the breakaway torque is a factor of at least 1.3 to 1.4, 30% to 40% safety should be included when sizing the single acting quarter turn actuator. Single acting quarter turn actuators can close or open with spring force as a safety function.

Sizing example:

Data given:

Torque needed by valve: 80 Nm (=100%)

Air supply in the system: 6 Bar

Step 1:

Calculate the torque needed including safety.

Because of the operating conditions a safety factor of 40% is applied

The calculated torque by considering a safety factor of 40%: $140\% \times 80 = 112 \text{ Nm}$

Step 2:

Check the table of spring return actuators' output

Accordinging the table we find output torque of PM 255 SR 11

Air stroke start = 186 Nm

Air stroke end = 128 Nm

Spring stroke end = 115 Nm

Spring stroke start = 173 Nm

All the output torque is larger than we needed. This data is showing the actuators torque can satisfy the requirement of the valves.

Attention:

During the restoration, the spring return actuators output torque will not be affected by the inputting air from the port B.

On the contrary, it will help the restoration of the springs.

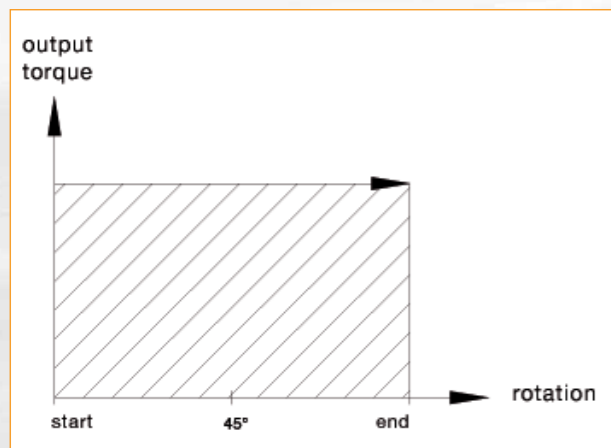

Fig. 8

During selection the spring return actuators we can choose the more reasonable and more economical actuators. If we know the different torque needed by the valve working at opening, operating and closing.

The 3 diagrams below show the calculated breakaway torques and closing torques using the typical torque characteristics of a butterfly valve and the torque lines of quarter turn pneumatic actuator. These were selected using the torque tables.

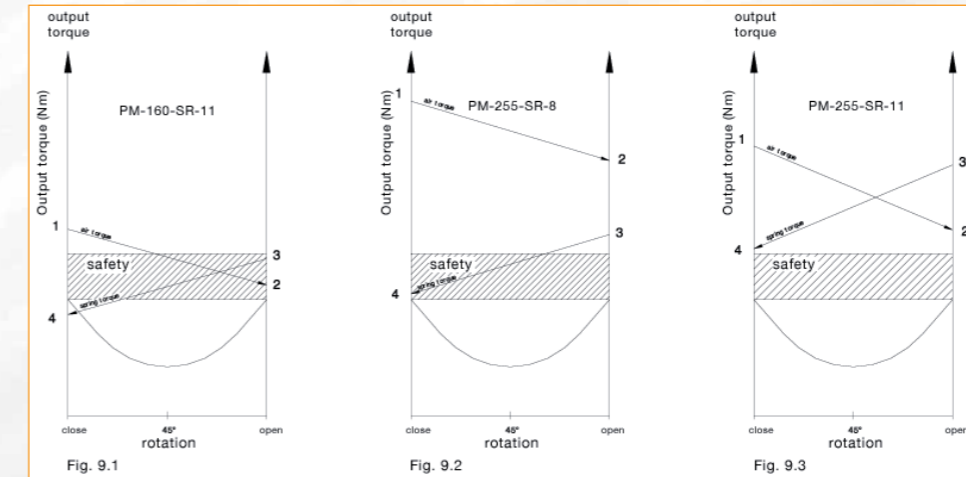

Fig. 9.1

The quarter turn actuator in Figure 9.1 is not suitable for this application as the low closing torque is not enough to close valve. (3→4)

Fig. 9.2

The use of the actuator shown in Figure 9.2 is critical as the closing torque of the springs (4) is only slightly above the breakaway torque of the valve. Even small pressure increases in the piping or pressure drops in the compressed air system will stop the valve from closing completely.

Fig. 9.3

The ideal quarter turn actuator in this case is shown in Figure 9.3. The breakaway and closing torques of the actuator are above the torque values incl. safety factor (40%) calculated for this valve when both opening and closing. This guarantees a reliable actuator function.

Torques (Nm)		(6 bar air pressure)		
		Fig. 9.1	Fig. 9.2	Fig. 9.3
		PM-160-SR-11	PM-255-SR-8	PM-255-SR-11
Air torque	max. 1	128,7 Nm	217 Nm	186 Nm
	min. 2	90,1 Nm	176 Nm	128 Nm
Spring torque	max. 3	108,3 Nm	125 Nm	173 Nm
	min. 4	69,6 Nm	84 Nm	115 Nm

rev.01 13-02-09

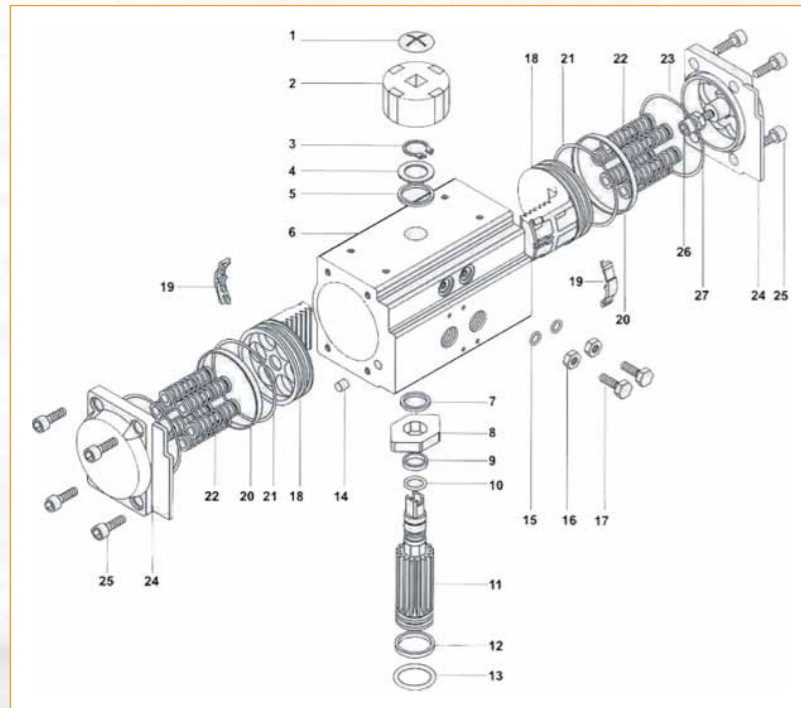

Fig. 2

no.	Description	Qty.	Standard material	protection	optional materials
1	Indicator screw	1	plastic		
2	Indicator	1	plastic		
3	Spring clip	1	stainless steel		
4	Thrust washer	1	stainless steel		
5	Outside washer	1	engineering plastic		
6	Body	1	extruded aluminium alloy	hard anodized etc.	
7	engineering plastic	1	engineering plastic		
8	Cam	1	Alloy steel		
9	Bearing (pinion top)	1	engineering plastic		
10	O-ring (pinion top)	1	NBR		Viton/silicone
11	Pinion	1	Alloy steel	Nickel plated	
12	O-ring (pinion bottom)	1	NBR		
13	Bearing (pinion bottom)	1	engineering plastic		
14	Plug	2	engineering plastic		
15	O-ring (adjust screw)	2	NBR		Viton/silicone
16	Nut (adjust screw)	2	stainless steel		
17	Adjust screw	2	stainless steel		
18	Piston	2	cast aluminum/casting	anodized /Zinc galvanized	
19	Guide (piston)	2	engineering plastic	anodized /Zinc galvanized	
20	Bearing (piston)	2	engineering plastic		
21	O-ring (piston)	2	NBR		Viton/silicone
22	Spring	0-12	Spring steel	dip coating	
23	O-ring (end cap)	2	NBR		Viton/silicone
24	End cap	2	cast aluminum/casting	powder polyester painted	
25	Cap screw	8	stainless steel		
26	Stop screw	2	stainless steel		
27	Nut (stop screw)	2	stainless steel		

Air consumption

An example for the influence of the compressed air pressure.

If the available airtorque falls to 136Nm or 78Nm because of a pressure drop from 6 bar to 5 bar for the actuator in figure 9.3, than it is obvious that the chosen actuator (PM-255-SR-11) is no longer sufficient for this application. For this reason: particular attention must be paid to the constant available minimum air pressure when sizing a quarter turn actuator. Note that all single acting actuators are more often than not 1 2 sizes larger than the double-acting actuators for the same process valve because of the reduced available torques on the air side. In the case of actuators that open using spring force (rotation of the piston by 180° to reverse the direction of rotation) the springs must apply the breakaway torque and the air torque must be large enough to be able to close the valve once more.

$$L/min = \text{Air volume (air volume opening + air volume closing)} \times \left[\frac{\text{air supply (Kpa)} + 101,3}{101,3} \right] \times \text{Action cycle times (/min)}$$

Air volume opening & closing (L/min.)

model	Air volume opening	Air volume closing	model	Air volume opening	Air volume closing
PM-012	0,08	0,07	PM-665	3,70	3,20
PM-020	0,12	0,16	PM-1000	5,90	5,40
PM-035	0,21	0,23	PM-1200	7,50	7,50
PM-050	0,30	0,34	PM-1800	11,00	9,00
PM-075	0,43	0,47	PM-2700	17,00	14,00
PM-110	0,64	0,73	PM-3000	36,80	28,90
PM-160	0,95	0,88	PM-3500	54,90	43,90
PM-255	1,60	1,40	PM-4000	78,60	65,80
PM-435	2,50	2,20			

rev. 03 13-02-2009

Weight

Weight table

model	PM-012	PM-020	PM-035	PM-050	PM-075	PM-110	PM-160	PM-255	PM-435
	(Ø40)	(Ø52)	(Ø63)	(Ø75)	(Ø83)	(Ø92)	(Ø105)	(Ø125)	(Ø140)
double acting (DA)	0,80 kg	1,38 kg	2,03 kg	2,70 kg	3,13 kg	4,60 kg	6,77 kg	8,90 kg	13,25 kg
single acting (SR)	-	1,45 kg	2,05 kg	2,90 kg	3,60 kg	5,22 kg	6,85 kg	10,11 kg	15,55 kg

model	PM-665	PM-1000	PM-1200	PM-1800	PM-2700	PM-3000	PM-3500	PM-4000
	(Ø160)	(Ø190)	(Ø210)	(Ø240)	(Ø270)	(Ø300)	(Ø350)	(Ø400)
double acting (DA)	20,14 kg	31,30 kg	46,80 kg	67,28 kg	96,90 kg	120,10 kg	192,50 kg	283,00 kg
single acting (SR)	24,00 kg	35,25 kg	54,80 kg	80,20 kg	118,00 kg	196,60 kg	250,50 kg	344,50 kg

rev. 03 13-02-2009

Spring mounting form for spring return actuators

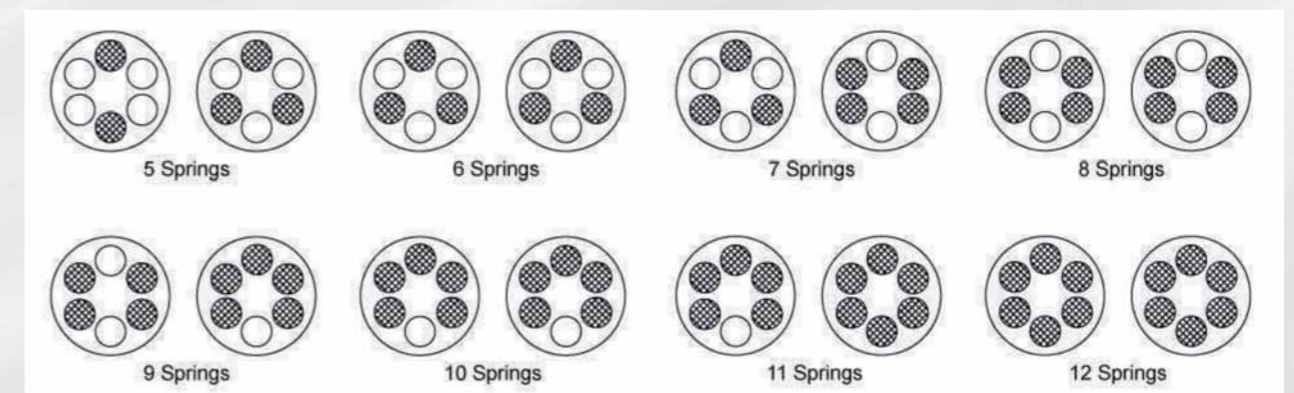

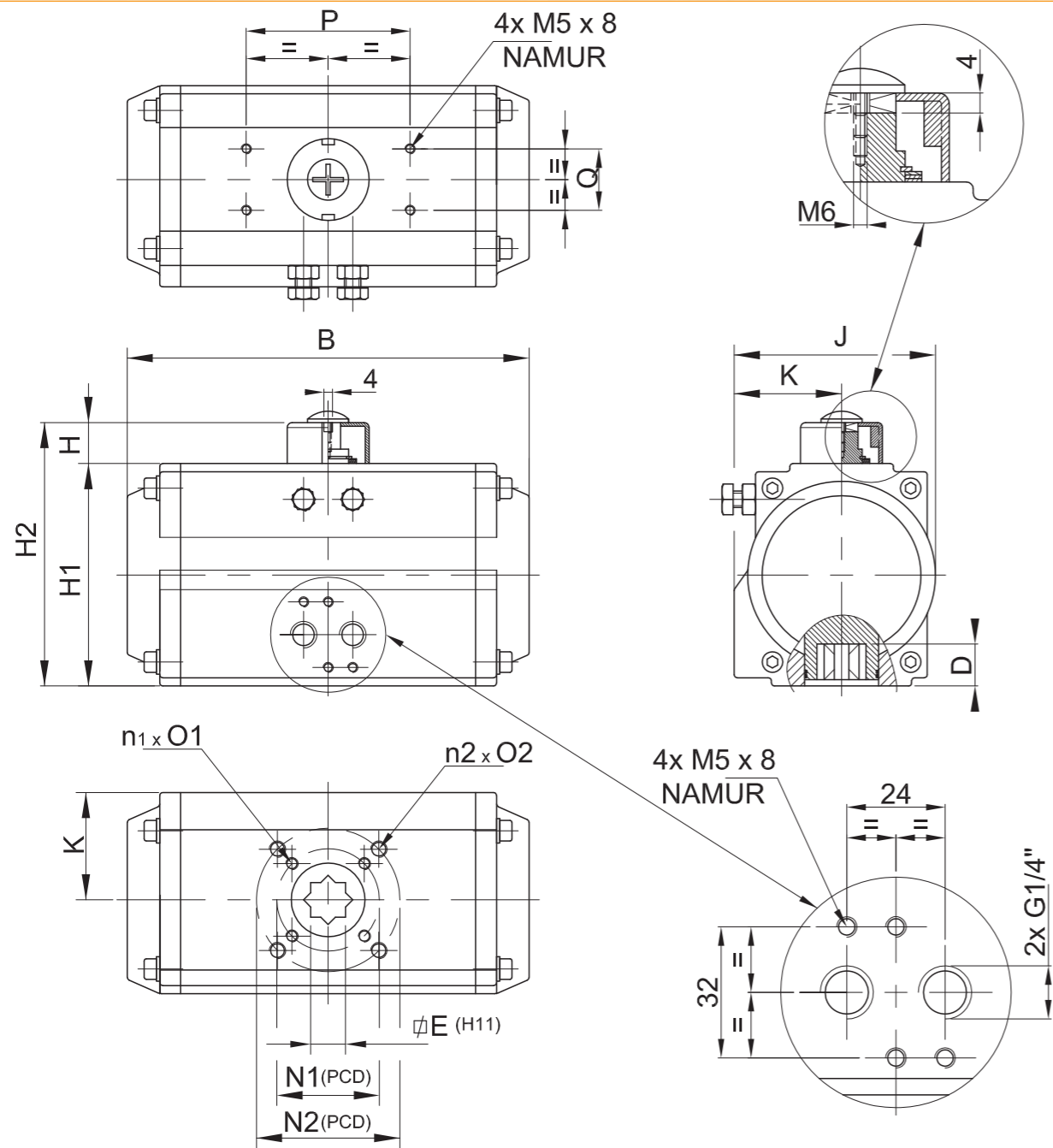

Actuator type (double acting)	Actuator type (Single acting/spring return)	$\square E (H11)$	D	B	J	H1	H2	K	N1	n1 x O1	N2	n2 x O2	Switchbox conn.		
													H	P	Q
PM 012 DA	PM 012 SR	11	14	122	65	60	85	36.5	36	4xM5	50	4xM6	20	80	30
PM 020 DA	PM 020 SR	11	14	147	71.5	74	94	41.5	36	4xM5	50	4xM6	20	80	30
PM 035 DA	PM 035 SR	14	18	168	83	88	108	47	50	4xM6	70	4xM8	20	80	30
PM 050 DA	PM 050 SR	14	18	184	95	100	120	53	50	4xM6	70	4xM8	20	80	30
PM 075 DA	PM 075 SR	17	21	204	103	109	129	57	50	4xM6	70	4xM8	20	80	30
PM 110 DA	PM 110 SR	17	21	262	108.5	120	140	58.5	50	4xM6	70	4xM8	20	80	30
PM 160 DA	PM 160 SR	22	26	268	121.5	133	153	64	70	4xM8	102	4xM10	20	80	30
PM 255 DA	PM 255 SR	22	26	301	142	155	175	74.5	70	4xM8	102	4xM10	20	80	30
PM 435 DA	PM 435 SR	27	31	390	152	171.5	191.5	77	102	4xM10	125	4xM12	20	80	30
PM 665 DA	PM 665 SR	27	31	458	174	197	217	87	102	4xM10	125	4xM12	20	80	30
PM 1000 DA	PM 1000 SR	36	50	525	206	230	260	103			140	4xM16	30	130	30
PM 1200 DA	PM 1200 SR	36	50	532	226	255	285	113			140	4xM16	30	130	30
PM 1800 DA	PM 1800 SR	46	60	602	260	291.4	321.4	130			165	4xM20	30	130	30
PM 2700 DA	PM 2700 SR	46	60	722	294	320	350	147			165	4xM20	30	130	30
PM 3000 DA	PM 3000 SR	46	60	830	389	362	392	194.5	165	4xM20	254	8xM16	30	130	30
PM 3500 DA	PM 3500 SR	55	70	920	443	412.7	432.7	221.5	165	4xM20	254	8xM16	30	130	30
PM 4000 DA	PM 4000 SR	55	70	1012	496	464.9	494.9	248	165	4xM20	254	8xM16	30	130	30

02-2009

Limit Switch box

Our Limitswitch box is designed with advanced technology which is solid with a high level quality and performance.

Standard available:

- Aluminum enclosure
- Visual indication
- Available with 2x V3 switches or 2 NJ2v3N sensors for IA application
- Voltage range AC 250V 0.2A, DC 24V 150mA
- 8 points internal connection strip

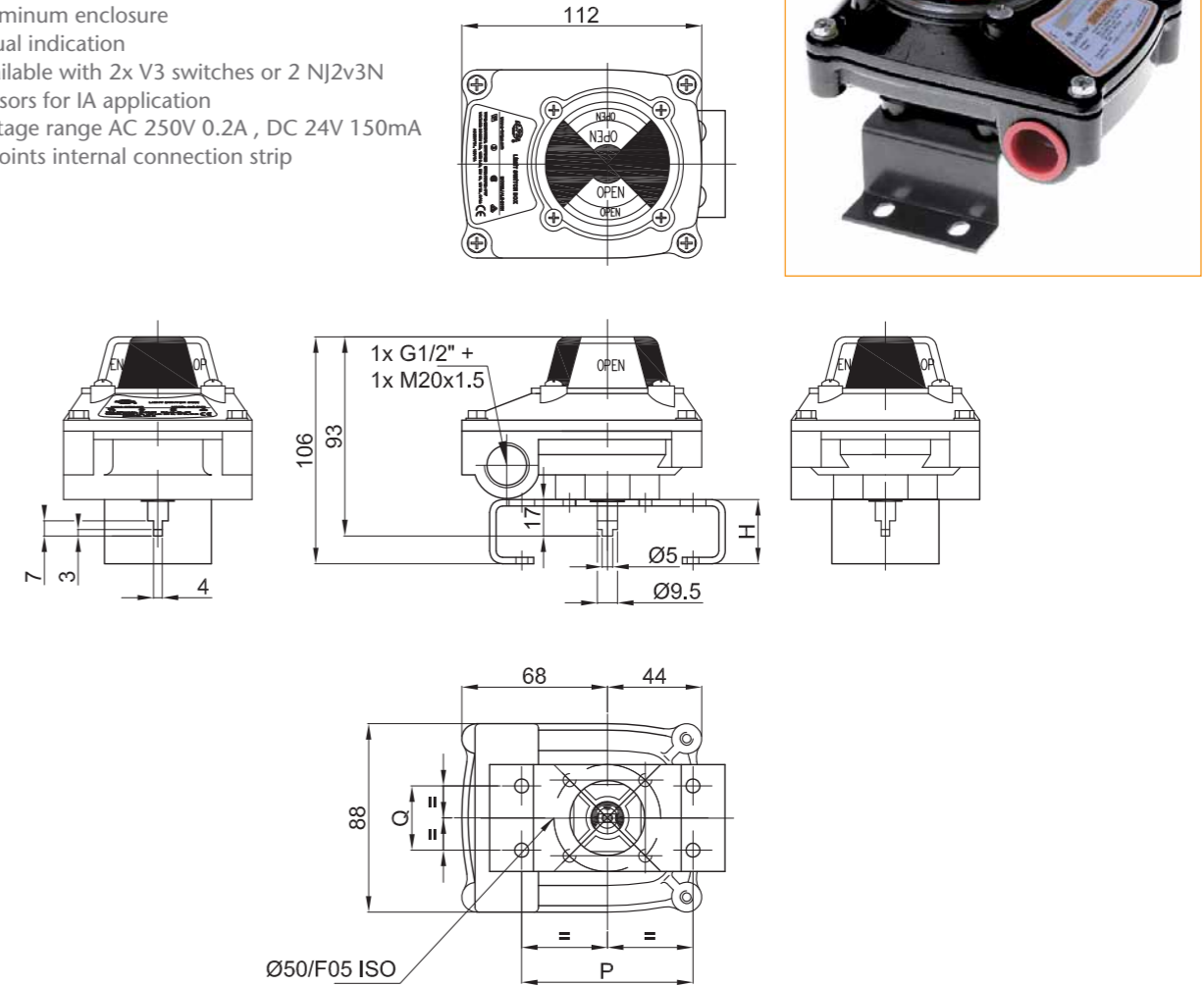

Switchbox SWB-2-PM- _ -

Item no.	Switch type	P (mm)	Q (mm)	H (mm)	Suitable for actuator type
SWB-2-PM-V3-02	2x V3	80	30	30	PM-012-__ up to PM-665-__
SWB-2-PM-V3-04	2x V3	130	30	40	PM-1000-__ up to PM-4000-__

General specifications:

- Continuous visual "3D" position indicator.
- Easy adjustable spring forced cam system
- Standard IP-67 enclosure
- Standard 2 pcs. OPEN/CLOSE mechanical switches.
- 2x V3 SPDT, 5A 125-250VAC
- Brackets suitable for all NAMUR - VDI/VDE interfaced actuators
- Terminal strip with 8 points to connect
- Working temperature -20°C - +80°C
- Cable entries 1x G1/2 + 1x M20 x 1.5

Material list

Part name	Material
Body	powder epoxy coated Die Cast Aluminium
Indicator	Plastic (transparent)
Fasteners	Stainless steel A4 (AISI-316)
Stem (drive shaft)	Stainless steel AISI-316
Seals	NBR

02-2009

Manual overrides

The PM pneumatic actuator is available with a manual override. This allows quick and simple operation when the air supply fails.

Standard available:

- Torques up to 5000Nm
- Standardised ISO mounting patterns to valve and actuator (acc. 5211)
- 3Cast iron body
- Stainless steel inputshaft
- Stainless steel fasteners
- IP68 sealing by NBR o-rings and gaskets
- High quality coated

The MO-D series are rugged, industrial grade manual overrides, manufactured with a cast iron housing. All models in this series feature high performance bearings and a polyurethane coated finish.

Applications

The PRO-MATIC MO-D series is designed to provide a manual operation of 90° for shut-off valves which are equipped with a pneumatic- or hydraulic actuator.

The MO-D series is providing a declutchable design for use in all industries where a reliable operation of both double acting and spring return pneumatic actuators, as well as hydraulic actuators is required.

All units which are to be mounted between the valve and actuator will be supplied with a (interchangeable) actuator mounting flange for flexible usage. Furthermore, all units can be supplied with the ISO drive shaft which is connecting the actuator with the valve.

Optionally, a 3/2 relief valve can be fitted on the housing in order to automatically evacuate air pressure from the actuator while engaging the manual override.



Gearbox type	Ratio	Torque Nm		M.A. ± 10%	Weight (Kg) excl. insert & adaptor
		Output	Input		
MO-D 350	44:1	350	31,25	11.2	6
MO-D 700	52:1	700	50	14.0	16.3
MO-D 1600	42:1	1.600	125	12.8	25
MO-D 3000	72:1	3.000	155	19.4	49.5
MO-D 5000	267:1	5.000	85	58.8	56

1Nm=0,737562 lbf.ft. 1Nm=8,8507 lbf.ins. [Converting International Units to British Units]

Performance specifications

- 5 Models
- Up to 5.000 Nm. Output Torque
- -5° to 95° stroke
- IP68 sealing
- -25°C to +110° C (-13° F to +230° F) temperature range

Features

- Stainless Steel inputshaft
- Stainless Steel fasteners
- Standardised according DIN / ISO 5211
- 5 Models up to 5.000 Nm. Output torque
- Axial needle bearings
- NBR 70 gasket material
- Sealed coupling by NBR O-ring
- Polyurethane coated finish
- Insert bush system for flexibility and reduced lead times (interchangeable with Q-series & X-series gearboxes)
- Blind tapped PCD's

Parts / Materials list			
Part-No	Description	Material	Specs / Standard
	Fasteners	Steel 8.8	
14	Excentric Lever	AISI-303/plastic	
13	Fixating bolt	Stainless steel	
12	Excentric Rack	Ductile-iron	GGG40 / ASTM 356
11	Grease	Complex	
10	Closing Plate Rack	Ductile-iron	GGG40 / ASTM 356
9	O-ring	Nitrile	NBR 70°Shore
8	Shaft	Stainless steel	AISI-303
7	Axial needle bearing		
6	Worm	Carbon Steel	C45-K
5	Quadrant	Ductile-iron	GGG40 / ASTM 356
4	Top Mounting Flange	Ductile-iron	GGG40 / ASTM 356
3	Coverplate	Ductile-iron	GGG40 / ASTM 356
2	Gasket	Nitrile	NBR 70°Shore
1	Body	Cast-iron	GG25 / ASTM A48

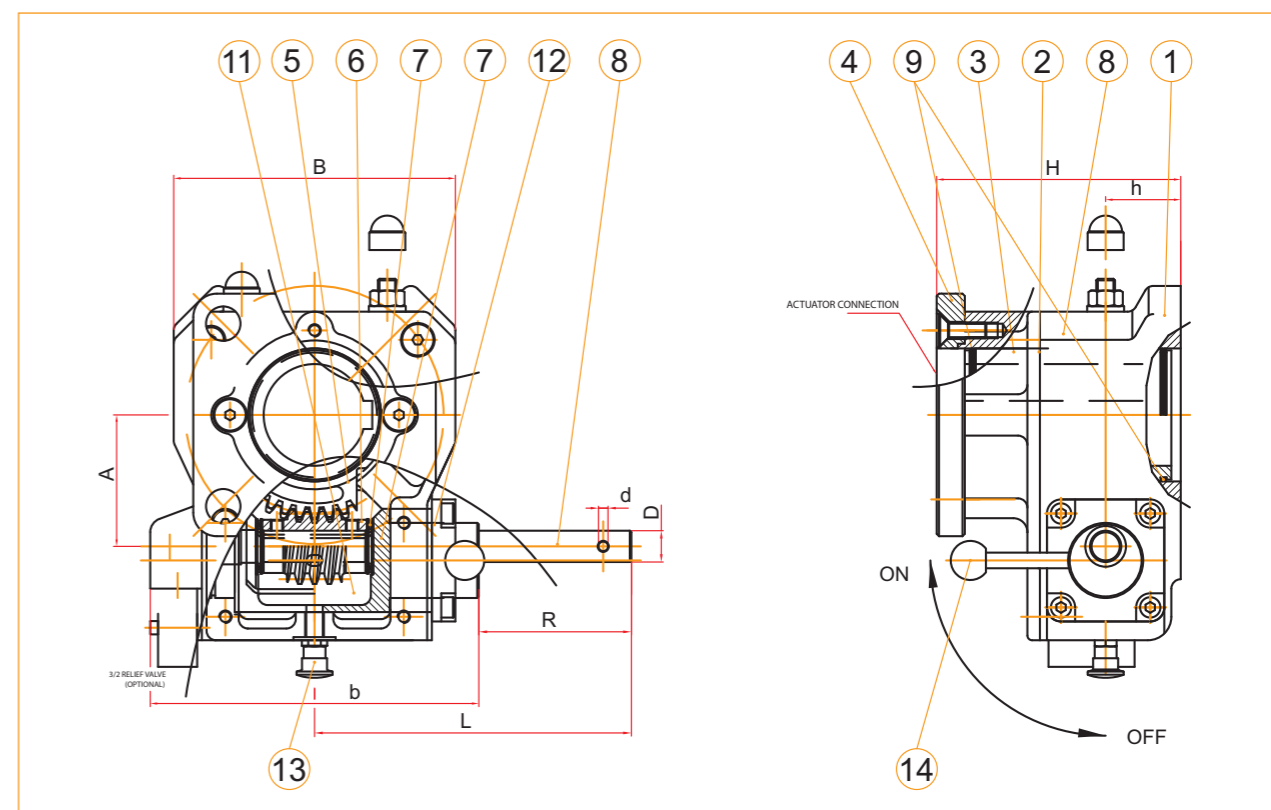

Gearbox type		A	b	B	d	D	h	H	L	R	valve connection Acc ISO 5211		actuator connection Acc ISO 5211	
MO-D 350	MM	52,5	143,5	112	4	12	34	122	148	78	70 (F07)	102 (F10)	70 (F07)	102 (F10)
	INCH	2,07	5,65	4,41	0,16	0,47	1,34	4,80	5,83	3,07	2,76	4,02	2,76	4,02
MO-D 700	MM	68,75	168	135	5	15	41	130	161	78	70 (F07)	125 (F12)	102 (F10)	125 (F12)
	INCH	2,71	6,61	5,31	0,20	0,59	1,61	5,12	6,34	3,07	2,76	4,92	4,02	4,92
MO-D 1600	MM	84	210	180	6,1	20	43	156	202,5	97,5	102 (F10)	140 (F14)	125 (F12)	140 (F14) 165 (F16)
	INCH	3,31	8,27	7,09	0,24	0,79	1,69	6,14	7,97	3,84	4,02	5,51	4,92	5,51 6,50
MO-D 3000	MM	132,5	280,5	282	6,1	20	56,5	201	250,5	105	165 (F16)	254 (F25)	165 (F16)	254 (F25)
	INCH	5,22	11,04	11,10	0,24	0,79	2,22	7,91	9,86	4,13	6,50	10,00	6,50	10,00
MO-D 5000	MM	132,5	395,5	282	6,1	20	56,5	201	378	110	165 (F16)	254 (F25)	254 (F25)	298 (F30)
	INCH	5,22	15,57	11,10	0,24	0,79	2,22	7,91	14,88	4,33	6,50	10,00	10,00	11,73

Solenoid valve

Our solenoid is a very rugged and reliable design, which can accept both AC and DC voltage. These solenoid valves are designed for years of performance and long life.

Standard available:

- Aluminum body
- Namur mounting pattern
- 3/2 or 5/2 execution
- Port size G1/4
- Pressure range 2.5 up to 8 bar
- Voltage range AC 220V 5,0 VA or DC 24V 4,8W 200mA

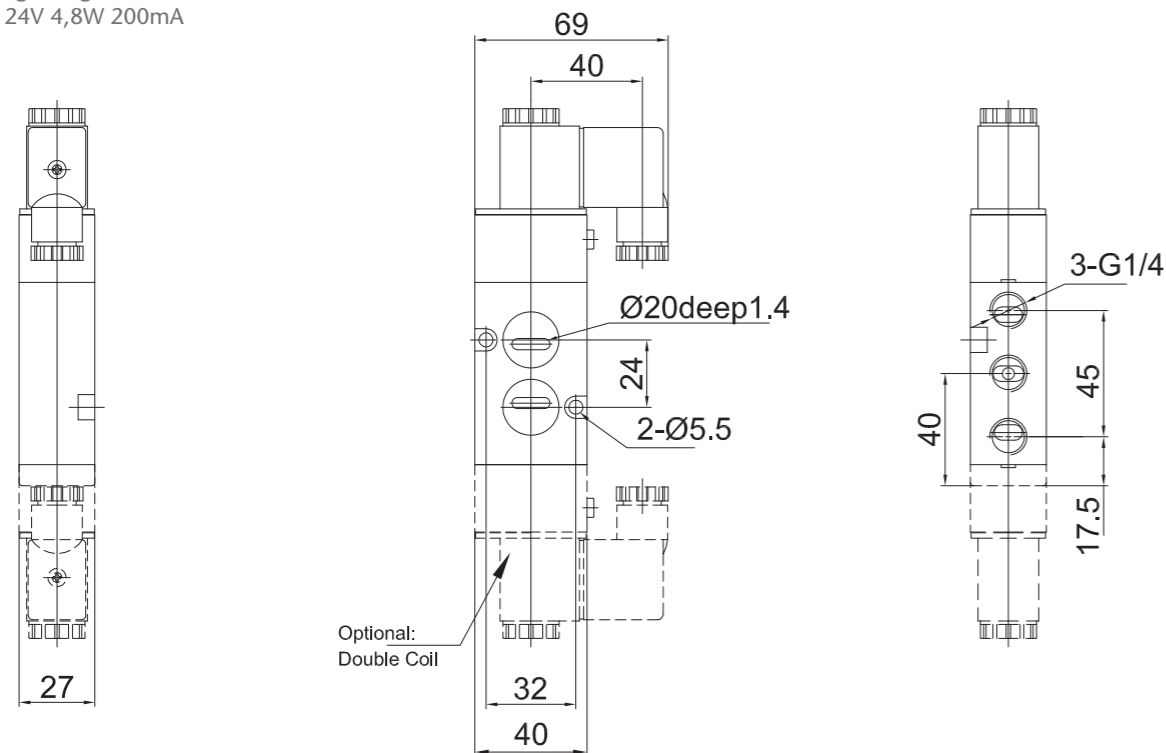

Schematic drawing 3/2 valve

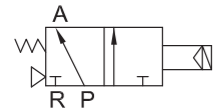

Schematic drawing 5/2 valve



General specifications:

- Direct mounting on NAMUR interface actuators.
- Easy convertible between 3/2 and 5/2 way (SR or DA) by replacing the o-ring position.
- Lockable manual operator.
- Standard IP65 enclosure single coil (spring return)
- Working temperature -10°C - +70°C

Optional:

- Dual coil construction

Solenoid

Model	
3W2P210-06B/08B	
5W2P210-06B/08B	

Material list

Part name	Material
Body	Aluminium (hard anodised)
Piston	Aluminium extrusion
Fasteners	Stainless steel A4 (AISI-316)
Spring	Stainless steel A4 (AISI-316)
Seals	NBR

Mounting brackets

Mounting kits and couplings for the PM pneumatic actuator can be designed and manufactured by Pro-Matic in accordance with ISO standards or customer requirements.

Available:

- Various materials and finishes
- ISO mounting patterns to valve and actuator
- Non-ISO patterns in accordance with specific customer requirements



