

**TECHNICAL REQUIREMENTS**

1. DESIGN AND MANUFACTURE PER ANSI B16.34
2. CONNECTION DIMENSIONS: ANSI B16.5
3. STANDARD MESH PERFORATION 1.6MM

NO	PART NAME	MATERIAL
1	BODY	A216 WCB
2	PRESSURE GAUGE	
3	MESH SCREEN	A182 F304
4	PLUG	A182 F304
5	GASKET	SS304 + GRAPHITE
6	BONNET BOLT	A193 B7
7	BONNET NUT	A193 2H
8	BONNET	A216 WCB

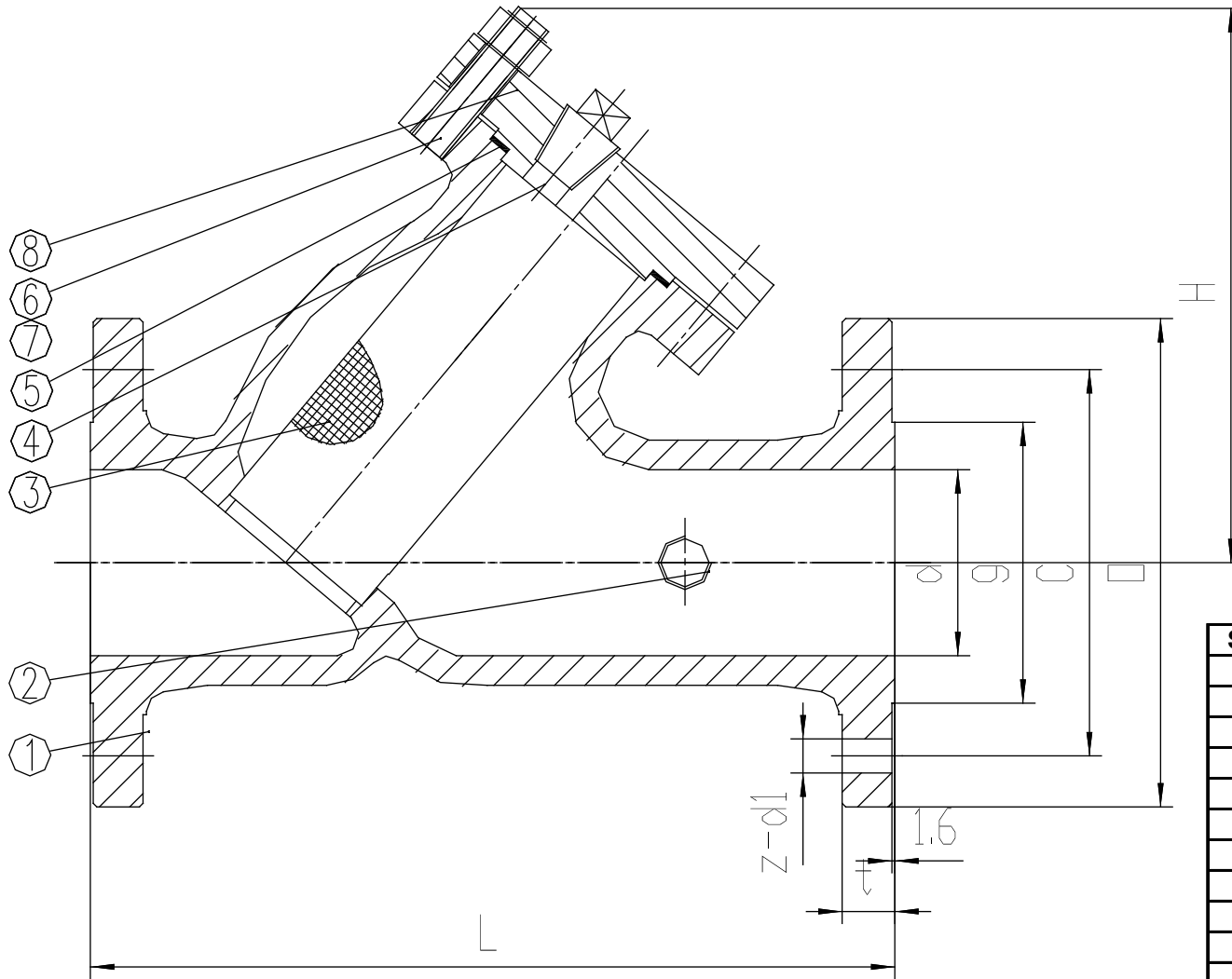

SIZE	d	L	H	O	C	g	t	Z - d1
15	15	147	63	89	60.5	40	12	4-16
20	20	152	68	98	70	54	13	4-16
25	25	160	95	108	79.5	60	13	4-16
40	38	200	128	127	98.5	73	15	4-16
50	51	203	167	152	120.5	92	16	4-20
65	64	216	180	178	139.5	105	18	4-20
80	76	241	200	190	152.5	127	19	4-20
100	102	292	230	229	190.5	157	24	8-20
150	152	406	316	279	241.5	216	26	8-23
200	203	495	450	343	298.5	270	9	8-23
250	254	622	500	406	362	324	31	12-26
300	305	698	650	483	432	381	32	12-26

REV B		
DATE	AUG 2011	<b>YST150</b>
SCALE	TO FIT	
<b>CAST STEEL Y-STRAINER ANSI 150</b>		