

INSTALLATION AND MAINTENANCE INSTRUCTIONS SCK - COMBINED SIGHT GLASS AND CHECK VALVE

GENERAL

- These instructions must be carefully read before any work involving products supplied by VALSTEAM ADCA ENGINEERING S.A. is undertaken.
- A Sight Check is a combined sight glass and check valve and it is used to observe discharges from steam traps. The position of the ball check indicates whether or not condensate is flowing. It eliminates the need for a separate check valve if the condensate rises after the trap. The installation procedure is a critical stage in a life of a sight glass and care should be taken to avoid damage of the equipment.

Warning!

- Do not touch the equipment without appropriate protection during working operation because it may conduct heat if the used fluid is at high temperature.
- Before starting maintenance be sure that the equipment is not pressurized or hot.
- Avoid spraying of hot sight glass with cold fluid, or failure could result.
- The equipment must be used within the working temperature and pressure limits laid down for them, otherwise they may fail (refer to nameplate and/or IS- Information Sheet).
- Do not remove the nameplate attached to the equipment. Serial number and other useful information is stamped on it.

INSTALLATION



- Before installation remove plastic covers placed on flanges or connection ends. The equipment has an arrow or Inlet/Outlet designations. Be sure that it will be installed on the appropriate direction.
- The SCK sight glasses can be installed in either a horizontal or vertical (bottom to top) pipe, on the outlet side of a steam trap.
- SCK should be fitted at least 1m from the trap to protect the glass from thermal pressure or shock.

MAINTENANCE

- The ADCA sight glasses do not require any particular maintenance. Cleaning or changing of the glass may become necessary from time to time. The cleaning intervals depend on the degree of contamination of the fluid. Examine the glass to ascertain the extend of any damage or service wear.
- When reassembling make sure that all gasket faces are clean and always use a new gasket. Tighten cover bolts uniformly in a diagonal sequence.
- For further information refer to the relevant IS (Information Sheet) or consult our Sales Office.

PARTS LIST FOR SIGHT CHECKER SCK:

CODE	DESIGNATION	TRAP SIZE DN	POS.NR.	QTY.
A.96.5200.015	Borosilicate glass tube & gaskets	1/2"-3/4"	3,7	1set
A.96.5200.025	Borosilicate glass tube & gaskets	1"	3,7	1set

Recommended tightening torques:

POS.NR.	TRAP SIZE DN	Nm
6	1/2"-3/4"	1,6-2,3
6	1"	1,8-2,5

Remarks: Tighten cover bolts uniformly.

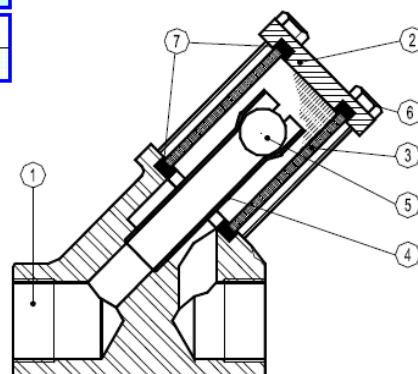

ATTENTION

- **LOSS OF WARRANTY:** Total or partial disregard of above instructions involves loss of any right to warranty.