

Mechanical Pinch Valves of OV series



Safety regulated . . .

 **Mechanical Pinch Valves:**
Valve solution for isolation and regulation

Even larger solid particles are shut off by the sleeve, which is particularly resistant to abrasion and corrosion, hence shut off without leaks.

Actuator variants:

Actuator variants available include manual actuation by means of a hand wheel or the automatic variant with double or single-acting pneumatic cylinders.

Mechanical Pinch Valves

- ▲ **The valve solution for abrasive, corrosive and fibrous products, granulates, powders and slurries.**

Valve function:

The manual valve is closed with handwheel.

The pneumatic valve is normally spring closed, air to open.

Furthermore a pinch valve with double acting cylinders is available.

Advantages:

- free passage
- hermetic closing
- optimum tightness
- no plugging
- easy maintenance

Safety function in the event of loss of energy/air of type PA/PA2

Construction:

Body and actuator aluminium, sleeves in various materials
(e.g. natural rubber anti-abrasive, EPDM, neoprene)

Maintenance:

The sleeves and other parts can be replaced easily

Body:

Aluminium

Sleeves:

Natural rubber or synthetic elastomers (i.e. NBR, CR, EPDM)

Sleeves in food grade on request.

Flange dimensions:

Acc. DIN EN 1092 PN10

Industrial areas:

- Pneumatic conveying systems
 - Cement and fibrocement
 - Pigment and granulates
 - Ceramics-, glass-, plastic industry
 - Sewage water and mud industry
 - Marble- and granite industry etc
 - Tannery
-

Mechanical Pinch Valves

OV series - type M

Pinch Valve with handwheel

Operation: Manual with handwheel

Opening/ closing mechanism: DN 15-50mm: single acting
DN 65-250mm: double

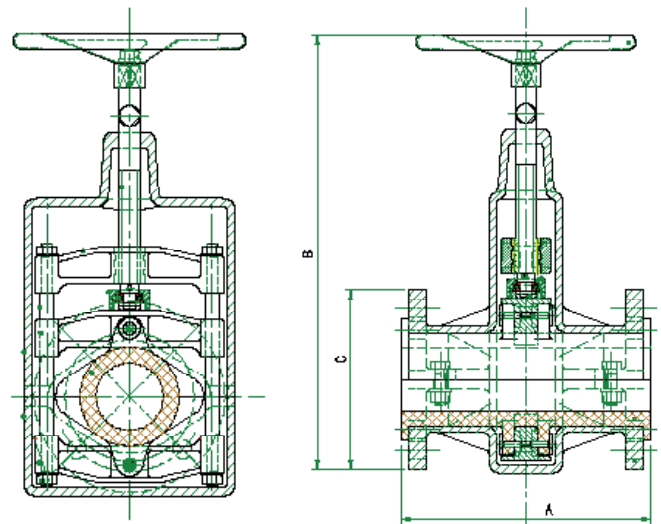

OV-M DN 15-250

DN	A	B	C	screws	TK* (mm)	d* (mm)	PS max (bar)	weight (kg)
15	162	195	95	4	65	14	5	1,8
20	162	205	105	4	75	14	5	1,9
25	196	230	115	4	85	14	5	2,7
32	196	260	140	4	100	18	5	3,0
40	216	275	150	4	110	18	5	4,0
50	246	295	165	4	125	18	5	5,0
65	256	455	185	4	145	18	5	11,5
80	276	485	200	4	160	18	5	13,0
100	316	525	220	8	180	18	5	17,0
125	325	645	250	8	210	18	3	25,5
150	325	745	285	8	240	22	3	30,0
175	355	850	315	8	270	22	3	45,0
200	370	860	340	8	295	22	3	45,0
250	524	1112	395	12	350	22	2	80,0

* = Flange connection: TK= pitch circle / d = bolt holes

Mechanical Pinch Valves

OV series - type PA/PA2

▲ Pinch Valve with pneumatic actuator

The valve is normally spring closed, air to open. (one/two single acting pneumatic cylinder)

Body+actuator: Aluminium

Accessories: Solenoid valve, pressure regulators, limit switches



OV-PA/PA2 DN 15-200

DN	A	B	C	screws	TK* (mm)	d* (mm)	PS max (bar)	weight (kg)	type
15	162	285	95	4	65	14	5	3,8	PA
20	162	300	105	4	75	14	5	4,0	PA
25	196	348	115	4	85	14	5	5,0	PA
32	196	386	140	4	100	18	5	5,5	PA
40	216	420	150	4	110	18	3	11,0	PA
50	246	438	165	4	125	18	3	12,0	PA
65	256	744	185	4	145	18	3	20,0	PA2
80	276	830	200	4	160	18	3	40,0	PA2
100	316	872	220	8	180	18	3	42,0	PA2
125	325	1080	250	8	210	18	3	58,0	PA2
150	325	1020	285	8	240	22	3	62,0	PA2
200	370	1229	340	8	295	22	2	95,0	PA2

* = Flange connection: TK= pitch circle / d = bolt holes

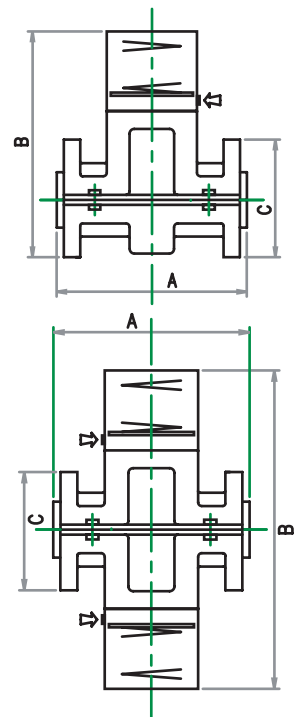

Mechanical Pinch Valves

OV series - type P/P2

▲ Pinch Valve with pneumatic actuator

The valve is pneumatically operated with one / two pneumatic cylinder (double acting).

Body+actuator: Aluminium

Accessories: Solenoid valve, pressure regulators, limit switches

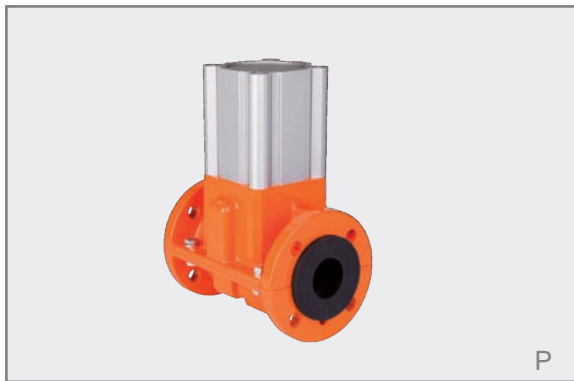

OV-P/P2 DN 15-250

DN	A	B	C	screws	TK* (mm)	d* (mm)	PS max (bar)	weight (kg)	type
15	162	194	95	4	65	14	5	2,5	P
20	162	201	105	4	75	14	5	2,7	P
25	196	208	115	4	85	14	5	3,5	P
32	196	233	140	4	100	18	5	3,6	P
40	216	320	150	4	110	18	5	7,0	P
50	246	338	165	4	125	18	5	7,5	P
65	256	440	185	4	145	18	5	15,0	P2
80	276	580	200	4	160	18	5	30,0	P2
100	316	600	220	8	180	18	5	33,0	P2
125	325	722	250	8	210	18	5	45,0	P2
150	325	792	285	8	240	22	5	50,0	P2
200	370	904	340	8	295	22	4	84,0	P2
250	524	1390	395	12	350	22	2	160,0	P2

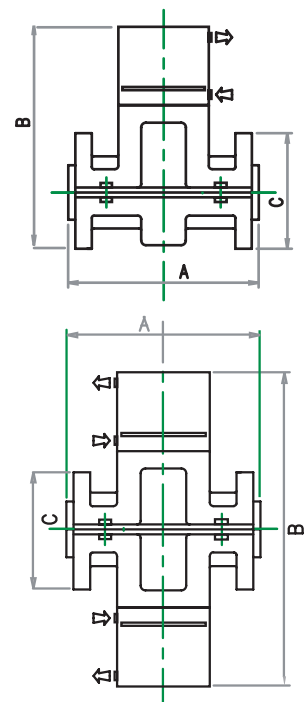

* = Flange connection: TK= pitch circle / d = bolt holes