



STAINLESS STEEL SAFETY VALVES

L9S

Sealing 1/2"~2"

L9-LS

Lever 1/2"~2"

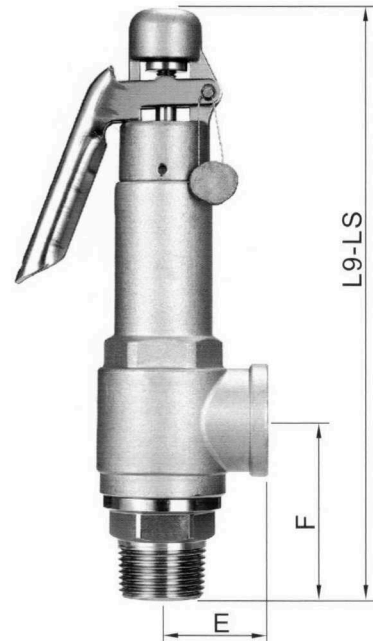
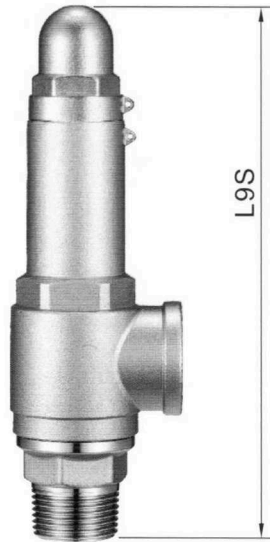
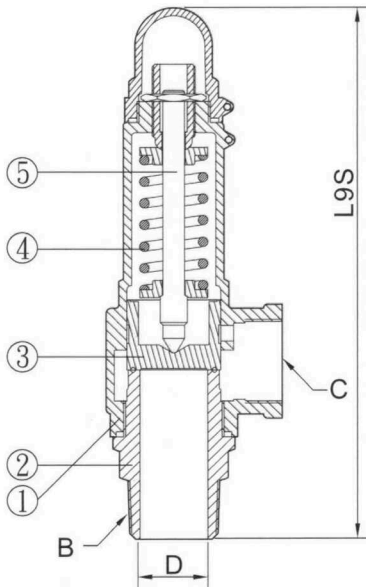

Dimensions

(Sealing)

Unit:mm

(Lever)

Unit:mm

Item Size	Unit:mm								Item Size	Unit:mm	
	L9S	Inlet B	Outlet C	Valve seat orifice D	E	F	Lift	Wt. kg		L9-LS	Wt. kg
1/2"	142	1/2"	1/2"	13	29	49	0.52	0.5	1/2"	168	0.6
3/4"	164	3/4"	3/4"	19	36	55	0.76	0.7	3/4"	190	0.8
1"	200	1"	1"	25	40	67	1.00	1.2	1"	222	1.3
1-1/4"	232	1-1/4"	1-1/4"	32	50	79	1.28	2.0	1-1/4"	248	2.0
1-1/2"	256	1-1/2"	1-1/2"	38	54	86	1.52	2.6	1-1/2"	272	2.7
2"	283	2"	2"	50	66	96	2.00	4.3	2"	306	4.4

General Material

NO.	Model		L9S Sealing	L9-LS Lever
	Parts Name			
1	Valve Body	CF8		
2	Valve Seat	SUS 304 or CF8		
3	Disc	SUS 304 or CF8		
4	Spring	SUS 304		
5	Stem	SUS 304		
Working Pressure		0.3~2 kgf/cm ²	2.1~10 kgf/cm ²	11~20 kgf/cm ²
Working Temp		-196 °C~290 °C		
Working Fluid		Noncorrosive Gas \ Corrosive Gas \ Air \ Steam		Noncorrosive Gas \ Corrosive Gas \ Air \ Steam

L9S 2" L9-LS 2" Working Pressure 11-20kgf/cm², Valve Seat orifice(D) 40mm