

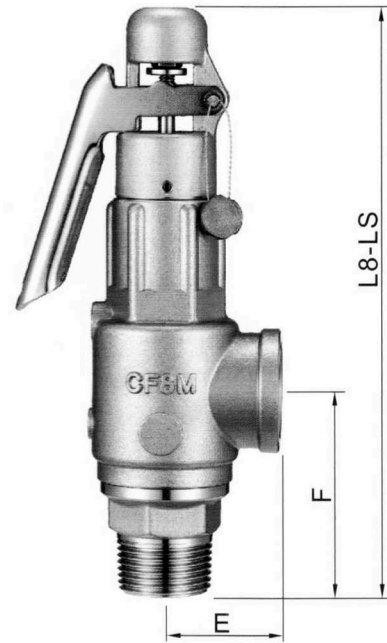

# STAINLESS STEEL SAFETY VALVES

**L8S Sealing 1/2"~2"**

**L8-LS Lever 1/2"~2"**

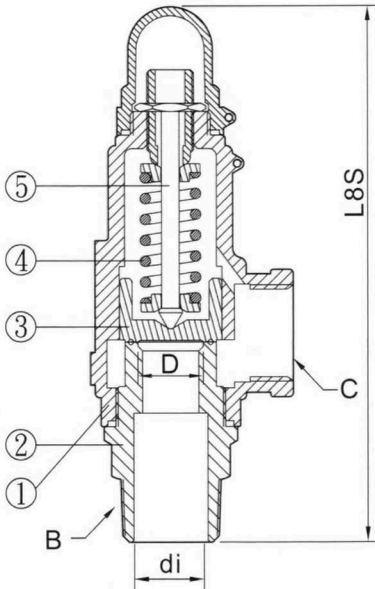

**Dimensions**

(Sealing)

Unit:mm

(Lever)

Unit:mm

Item Size	L8S	Inlet B	Outlet C	Inlet orifice di	Valve seat orifice D	E	F	Lift	Wt. kg	Item Size	L8-LS	Wt. kg
1/2"x1"	176	1/2"	1"	13	22	40	67	0.88	1.1	1/2"x1"	199	1.3
3/4"x1"	176	3/4"	1"	19	22	40	67	0.88	1.2	3/4"x1"	199	1.3
1"x1"	180	1"	1"	25	22	40	71	0.88	1.2	1"x1"	203	1.3
1-1/4"x2"	255	1-1/4"	2"	32	38	66	93	1.52	4.6	1-1/4"x2"	279	4.8
1-1/2"x2"	260	1-1/2"	2"	38	38	66	98	1.52	4.6	1-1/2"x2"	284	4.8
2"x2"	260	2"	2"	50	38	66	98	1.52	4.6	2"x2"	284	4.9

**General Material**

NO.	Parts Name	Model	L8S Sealing	L8-LS Lever
1	Valve Body	CF8M		
2	Valve Seat	SUS316 or CF8M		
3	Disc	SUS316 or CF8M		
4	Spring	SUS 304		
5	Stem	SUS 316		
Working Pressure			0.3~2 kgf/cm <sup>2</sup>	2.1~10 kgf/cm <sup>2</sup> 11~20 kgf/cm <sup>2</sup>
Working Temp			-196 °C~290 °C	
Working Fluid			Noncorrosive Gas、Corrosive Gas、Air、Steam	Noncorrosive Gas、Corrosive Gas、Air、Steam