



## 1. Description

The NP series knife gate is a unidirectional wafer valve used on industrial pipeline for on-off operation. The unique valve structure eliminates potential clogging shutoff when the valve is dealing with flow with particles. Beveled knife gate design also generates great shear stress for easy flow penetration.

## 2. Technical Data

**Size:** DN 50 to DN 600 (larger diameters on request)

**Working pressure:**

DN 50 to DN250	10 Bar	NPS 2-10	150 psi
DN 300 to DN450	7 Bar	NPS 12-18	90 psi
DN 500 to DN600	4 Bar	NPS 20-24	60 psi

**Standard flange connection:**

EN1092	GB/T 9113
ASME B16.5	AS 2129/4087
JIS B2220	Others on request

**Application:**

Pulp and Paper/ Mining /Waste Water Treatment/ Food and Beverage/Chemical Plants/ Power Plants/ Steel Industry/Etc.

### 3. Design Features

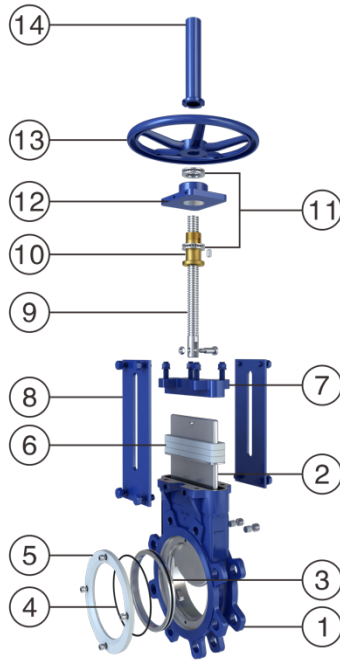

STANDARD PART LIST			
Parts	WCB	CF8	CF8M
1. Body	WCB	CF8	CF8M
2. Gate	304	304	316
3. Seat	Metal/Metal or EPDM		
4. O-ring	NBR		
5. Seat Retainer	WCB	CF8	CF8M
6. Packing	PTFE		
7. Gland	WCB	CF8	CF8M
8. Yoke	Q235	304	304
9. Stem	2Cr13	2Cr13	2Cr13
10. Stem Nut	Brass	Brass	Brass
11. Thrust Bearing	65Mn	65Mn	65Mn
12. Bearing Housing	WCB	WCB	WCB
13. Hand wheel	GGG30 (Epoxy Coated)		
14. Stem Protector	304	304	304
15. Fasteners	A2-70	A2-70	A4-70

**Note:** Hand wheel nut is available for valve without stem protector. Non-stainless parts are epoxy coated.

#### BODY:

- Cast-in guide claws at the port bottom for gate fixture, instead of a groove, eliminates potential valve shutoff clogging while providing tighter seal. The guide claws also push gate to seat for tight seal in closed position.
- Integral body design ensures easy assembly and 0 shell leakage.
- Full port design minimizes pressure drop and maximize flow capacity.
- PTFE resilient points against gate eliminate metal-metal contact between gate and body.

#### GATE:

- Beveled knife edge provides strong cutting stress and tight sealing.
- Gate thickness can be increased to meet higher pressure.
- Gate surface is well polished at both sides for tight seal and less jamming.
- Gate is hard chrome coated for metal sealing valve.

#### SEAT:

- Side-entry seat is replaceable, reducing the cost of maintenance.
- L-shape seat retainer locks seat into valve body and covers seat side to prevent direct flow flushing.

#### Other:

- Stem cover is available to ensure long service life for stem.
- Two thrust bearings minimizes torque for operation.
- Grease nipple is available to ease bearing lubrication.

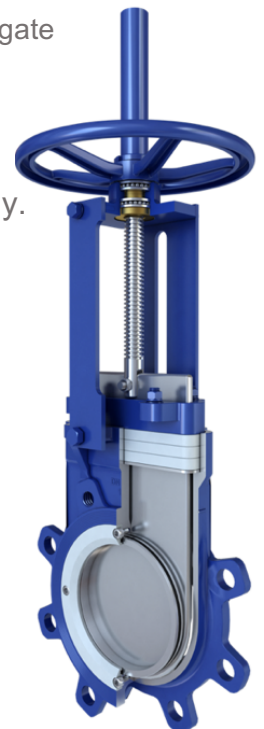

## 4. Actuator Options

### Manual

Hand wheel (Rising & Non-rising Stem)  
 Bevel Gear  
 Chain wheel  
 Lever

### Automatic

Electric  
 Pneumatic (single & double-acting)  
 Hydraulic

**\*Note: for other options, please contact us for availability.**

### Accessories

Actuator Manual Override  
 Stem Extensions  
 Positioners  
 Proximity Switches

Locking Device  
 Solenoid Valves  
 Limit Switches  
 ISO Mount

## 5. Other Options

V-PORT  
 Deflection Cone  
 Flushing Port

Fabricated Valve  
 Semi lug design  
 Other materials for valve

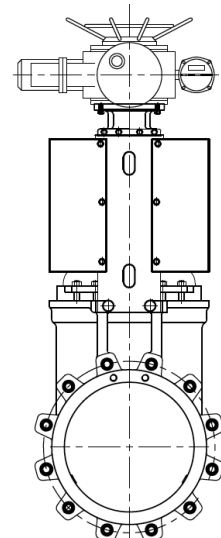
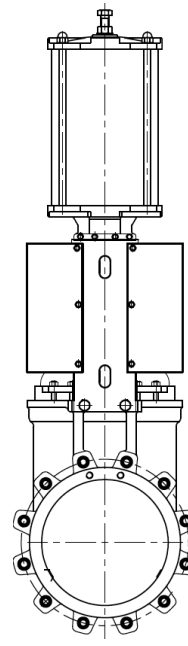
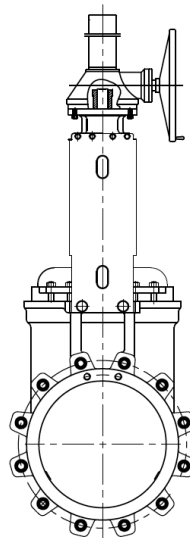
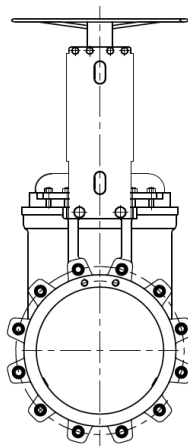
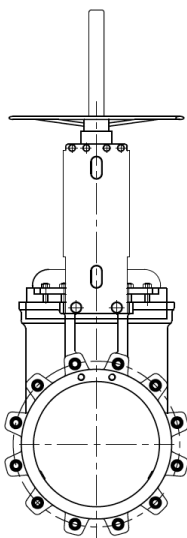
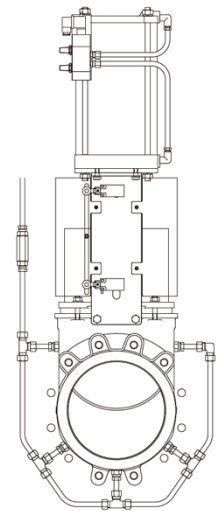

Rising Stem Valve

Non-rising Stem Valve

Bevel Gear Valve

Pneumatic Valve

Electric Valve

## Dimension I – Hand Wheel Operated Valve (Rising Stem)

- Standard Manual Actuator
- Including:
  - ⊕ Hand Wheel
  - ⊕ Stem
  - ⊕ Stem Nut
- Size Range:
  - ⊕ DN50-DN400
  - ⊕ Gearbox is suggested for size  $\geq$  DN 450
- Options:
  - ⊕ Stem Cover
  - ⊕ Side Cover for gate safety
  - ⊕ Plate-type Yoke
  - ⊕ Locking Device
  - ⊕ Extensions

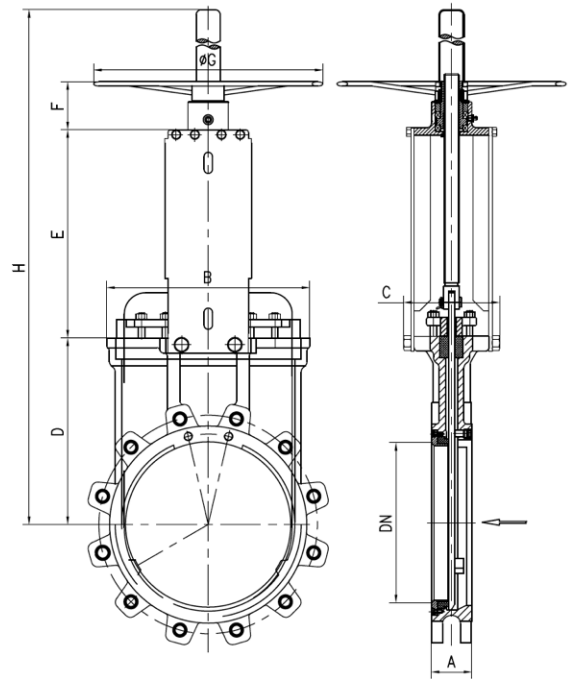

DN	A	B	C	D	E	F	G	H	Weight (kg)
50	48	135	106	100	129	85	180	395	9
65	48	155	106	115	147	85	180	436	11
80	51	175	106	121	168	85	200	478	12
100	51	163	106	138	192	85	200	545	16
125	57	192	120	160	215	87	250	630	20
150	57	216	130	185	245	87	280	705	25
200	70	271	130	235	302	105	300	890	43
250	70	335	140	300	355	105	350	1065	62
300	76	381	160	350	401	105	400	1200	78
350	76	436	180	400	465	117	450	1375	112
400	89	505	180	455	511	117	450	1525	154

## Dimension II – Hand Wheel Operated Valve (Non-rising Stem)

- Application: For the installation where space is limited
- Including:
  - ⊕ Hand Wheel
  - ⊕ Stem
  - ⊕ Stem Nut (fixed to gate)
- Size Range:
  - ⊕ DN50-DN400
  - ⊕ Gearbox is suggested for size  $\geq$  DN 450
- Options:
  - ⊕ Stem Cover
  - ⊕ Locking Device
  - ⊕ Extensions
  - ⊕ Bare Shaft

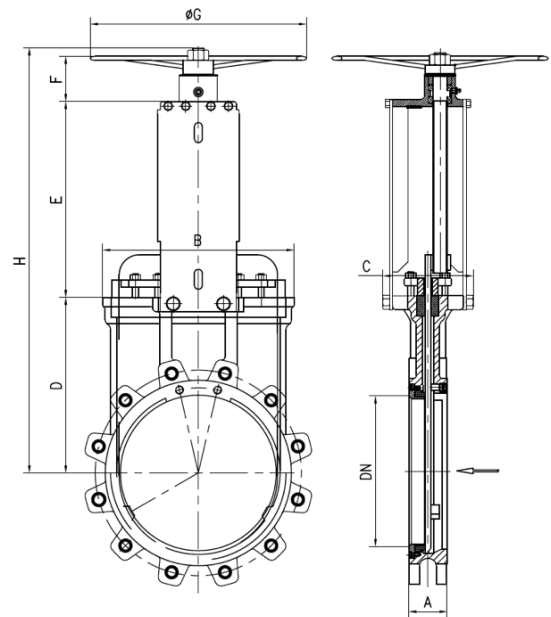

DN	A	B	C	D	E	F	G	H	Weight (kg)
50	48	135	106	100	129	85	180	315	9
65	48	155	106	115	147	85	180	350	11
80	51	175	106	121	168	85	200	375	12
100	51	163	106	138	192	85	200	415	16
125	57	192	120	160	215	87	250	465	20
150	57	216	130	185	245	87	280	520	25
200	70	271	130	235	302	105	300	645	43
250	70	335	140	300	355	105	350	760	62
300	76	381	160	350	401	105	400	860	78
350	76	436	180	400	465	117	450	982	112
400	89	505	180	455	511	117	450	1083	154

## Dimension III – Bevel Gear Operated Valve

- Mainly applied to valve size  $\geq$ DN450
- Including:
  - ⊕ Gearbox (Standard Ratio: 4.5:1) with hand wheel
  - ⊕ Stem
  - ⊕ Stem Protector
- Options:
  - ⊕ Locking Device
  - ⊕ Extension
  - ⊕ Chain wheel
  - ⊕ Rising/Non-rising Stem type

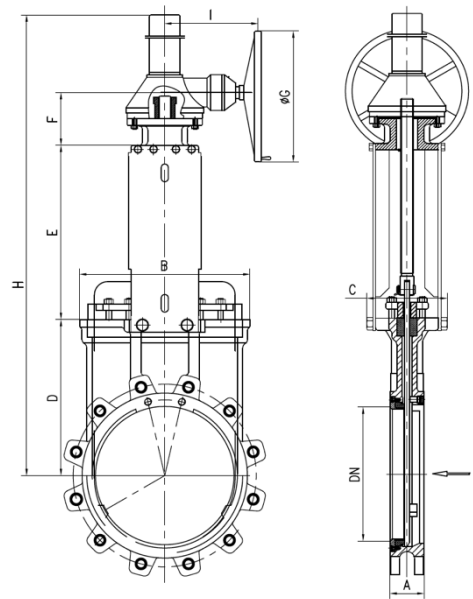

DN	A	B	C	D	E	F	G	H	I	Weight (kg)
200	70	271	130	235	302	105	310	1065	150	60
250	70	335	140	300	355	105	310	1230	150	88
300	76	381	160	350	401	105	310	1415	170	103
350	76	436	180	400	465	117	310	1590	170	163
400	89	505	180	455	511	117	310	1740	170	204
450	89	550	240	510	580	178	460	1810	233	238
500	114	600	270	560	640	178	460	1950	233	265
600	114	700	270	650	740	178	460	2205	233	300

## Dimension IV – Double Acting Pneumatic Valve

- Standard DA pneumatic actuator including:
  - ⊕ ≤DN200 : Aluminum Cylinder
  - ⊕ ≥DN250 : WCB cylinder (Epoxy Coated)
  - ⊕ WCB caps (Epoxy Coated)
  - ⊕ #45Steel+Cr Piston Rod
- Size Range: DN50-DN600
- Air Supply Pressure Range
  - ⊕ 4 bar to 7 bar.
- Options:
  - ⊕ Gate cover for safe operation
  - ⊕ Manual override
  - ⊕ Locking Device
  - ⊕ Air tank for fail-safe operation
  - ⊕ Limit Switch
  - ⊕ Positioner
  - ⊕ Solenoid Valve
  - ⊕ Flow Regulator

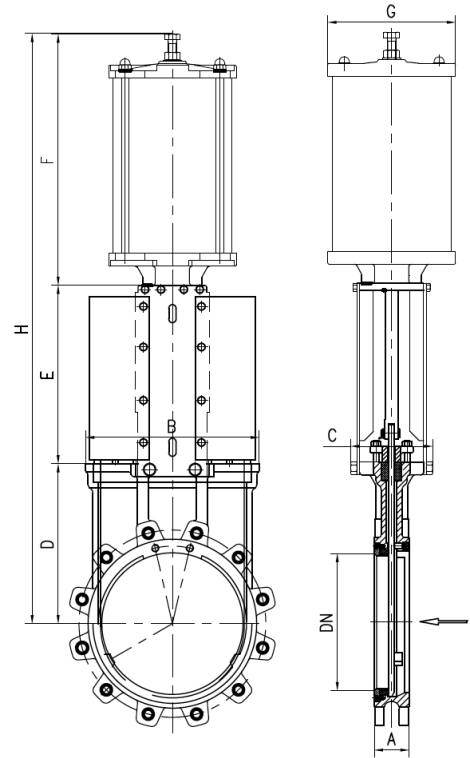

DN	A	B	C	D	E	F	G	H	Cylinder	Connect	Weight (kg)
50	48	135	106	100	129	230	100	460	C80/60	F1/4	15
65	48	155	106	115	147	245	100	510	C80/75	F1/4	17
80	51	175	106	121	168	270	120	560	C100/85	F1/4	18
100	51	163	106	138	192	300	120	630	C100/100	F1/4	22
125	57	192	120	160	215	330	150	705	C125/135	F1/4	29
150	57	216	130	185	245	350	150	780	C125/160	F1/4	34
200	70	271	130	235	302	440	195	980	C160/210	F3/8	69
250	70	335	140	300	355	505	240	1160	C200/260	F3/8	101
300	76	381	160	350	401	550	280	1300	C250/310	F3/8	138
350	76	436	180	400	465	620	380	1485	C250/360	F3/8	210
400	89	505	180	455	511	670	395	1640	C300/410	F3/8	250
450	89	550	240	510	580	710	395	1800	C300/460	F3/8	310
500	114	600	270	560	640	800	425	2000	C320/510	F3/8	347
600	114	700	270	650	740	910	425	2300	C320/610	F3/8	392

## Dimension V – FLANGE AND BOLTING DETAILS

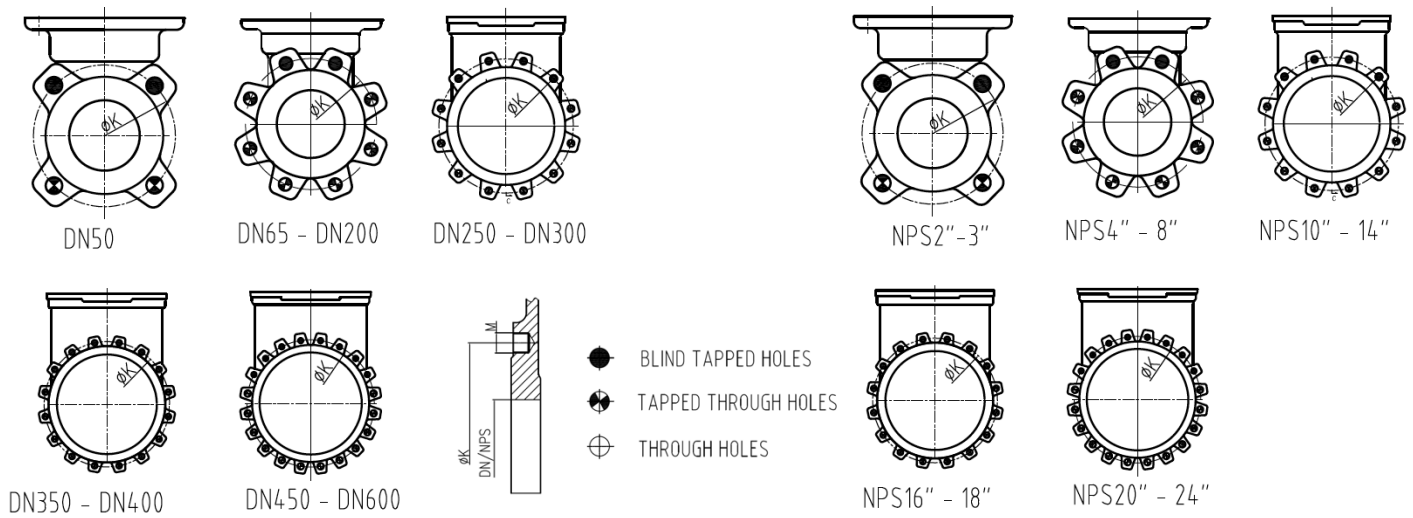

### EN 1092

DN	K	n°	M	T	
50	125	4	M-16	11	2 - 2 - 2
65	145	4	M-16	11	2 - 2 - 2
80	160	8	M-16	11	2 - 6 - 6
100	180	8	M-16	11	2 - 6 - 6
125	210	8	M-16	11	2 - 6 - 6
150	240	8	M-20	14	2 - 6 - 6
200	295	8	M-20	14	2 - 6 - 6
250	350	12	M-20	18	4 - 8 - 8
300	400	12	M-20	18	4 - 8 - 8
350	460	16	M-20	22	6 - 10 - 10
400	515	16	M-24	24	6 - 10 - 10
450	565	20	M-24	24	8 - 12 - 12
500	620	20	M-24	24	8 - 12 - 12
600	725	20	M-27	24	8 - 12 - 12

### ANSI B16.5

DN	K	n°	M	T	
2"	4 3/4"	4	5/8" UNC	3/8"	2 - 2 - 2
2 1/2"	5 1/2"	4	5/8" UNC	3/8"	2 - 2 - 2
3"	6"	4	5/8" UNC	3/8"	2 - 2 - 2
4"	7 1/2"	8	5/8" UNC	3/8"	2 - 6 - 6
5"	8 1/2"	8	3/4" UNC	3/8"	2 - 6 - 6
6"	9 1/2"	8	3/4" UNC	1/2"	2 - 6 - 6
8"	11 1/2"	8	3/4" UNC	1/2"	2 - 6 - 6
10"	14 1/2"	12	7/8" UNC	3/4"	4 - 8 - 8
12"	17"	12	7/8" UNC	3/4"	4 - 8 - 8
14"	18 1/2"	12	1" UNC	7/8"	4 - 8 - 8
16"	21 1/2"	16	1" UNC	1"	6 - 10 - 10
18"	22 1/2"	16	1 1/8" UNC	1"	6 - 10 - 10
20"	25"	20	1 1/8" UNC	1"	8 - 12 - 12
24"	29 1/2"	20	1 1/4" UNC	1"	8 - 12 - 12



---

## Appendix – Actuator Selection Data

DN	Thrust (N)	Torque (N*M)	NO. of Turns	Stem Size
50	2000	24	15	Tr20*4 LH
65	2300	32	18	Tr20*4 LH
80	2800	35	23	Tr20*4 LH
100	3900	42	28	Tr20*4 LH
125	5600	59	28	Tr22*5 LH
150	6750	78	33	Tr22*5 LH
200	10000	108	37	Tr28*6 LH
250	16000	180	45	Tr28*6 LH
300	25000	219	52	Tr28*6 LH
350	31800	272	60	Tr32*6 LH
400	37500	345	69	Tr32*6 LH
450	40000	488	66	Tr35*6 LH
500	47000	578	73	Tr40*7 LH
600	54000	735	88	Tr40*7 LH

**Note:** Thrust and Torque data are reference for normal application, for specific conditions, please contact us for further support.