

DAV-P-KA

This valve has been designed for efficient discharge and intake of air in water transport systems, filtering systems, containers, and other places where confined air could impair the system's operation.

The valve is appropriate for:

- Expelling the air at high flow velocity during the initial filling of the systems
- Introducing large quantities of air when the pipe drains, maintaining atmospheric pressures in the pipe and preventing collapse and cavitation damage to the conduits
- Relieving the entrained air from the water, while the network is pressurized

Properties:

Leak-proof sealing at all conditions, including low system pressure. The aerodynamic design of the float provides air flow at a very high velocity. The float does not close before the water has reached the valve. Threaded outlet elbow allows various possibilities of drain connection. The valve design contains a very limited number of parts, allowing an easy dismantling for maintenance.

Operation:

The DAV-P-2-KA valve has three modes of operation: Discharge of large quantities of air at a high flow velocity when the conduit is being filled. When the water arrives to the valve, the main float rises up and closes the outlet. Introduction of air into the pipeline when the internal pressure is sub-atmospheric. The pressure difference forces the main float to drop to "opened" position, allowing the air to flow into the pipe. Releasing entrained air from the pipeline. Small quantities of diluted air accumulate in high peaks of the pipeline and in the peak of the valve. The pressurized air expels the water. The descending water level moves the main float with it. At a



certain position the main float pulls down the small seal, that partially opens the nozzle. The pressurized air can escape, the water level rises and the nozzle re-closes.

Technical Specifications

- Operating pressure of 0.1 bar / 1.5 psi to 16 bar / 230 psi
- Maximal water temp. for continuous operation: 60°C / 140°F
- Maximal water temp. for intermittent operation: 80°C / 175°F
- 1/2", 3/4", 1", 2" BSP or NPT threaded base - as per the customer's choice
- Structure materials:
 - Cover - GRP (UV resistant) / Polypropylene Base - GRP / Polypropylene or Brass
- Internal parts: corrosion resistant plastic materials and synthetic rubber
- At pipe pressure of 0.5 bar / 7 psi:
 - The 2"/50mm valve allows the discharge of 260 m³/h / 153 CFM of air
 - The 1"/25mm valve allows the discharge of 60 m³/h / 35 CFM of air

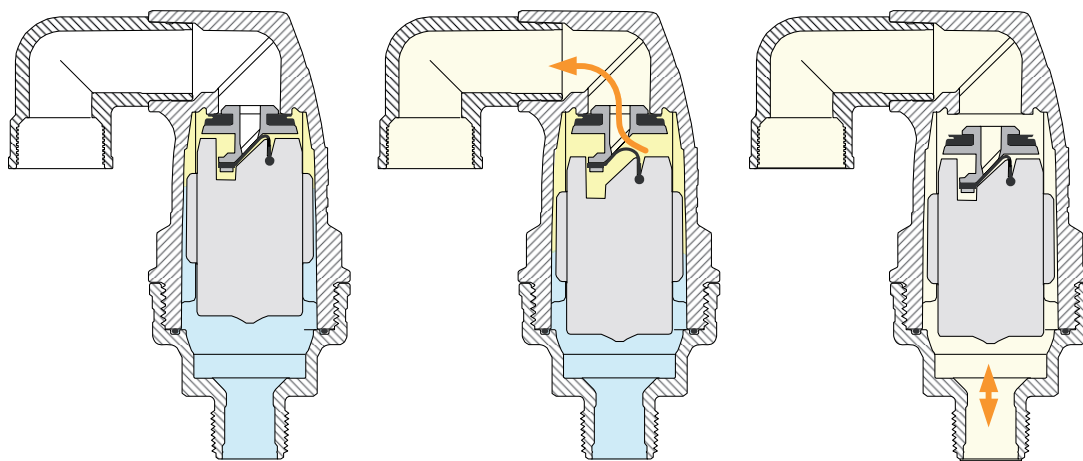
Principle of operation:

Pipe is full of water

Dissolved air is accumulated in the valve, released when the float drops down

Pipe is aerated

Parts list and specifications:

Part	Description	Material
1	Body	Glass Reinforced Nylon Optional: Brass, Polypropylene
2	Bonnet	Glass Reinforced Nylon Optional: Polypropylene
3	Float	Foamed Polypropylene
4	Slider	Glass Reinforced Nylon
5	Automatic Seal	EPDM
6	Kinetic Seal	EPDM
7	O ring	NBR
8	Drainage Elbow	Polypropylene

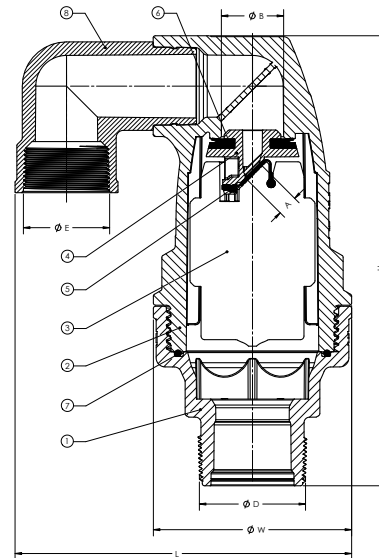

Dimensions:

Valve	12 mm / 1/2"		20 mm / 3/4"		25 mm / 1"		50 mm / 2"	
	SI	US	SI	US	SI	US	SI	US
H - Height	183 mm	7 1/4"	183 mm	7 1/4"	183 mm	7 1/4"	249 mm	9 7/8"
W - Width	86 mm	3 1/3"	86 mm	3 1/3"	86 mm	3 1/3"	110 mm	4 1/3"
D - Thread	1/2" BSP	1/2" NPT	3/4" BSP	3/4" NPT	1" BSP	1" NPT	2" BSP	2" NPT
A - Nozzle Area	12.85 mm ²	0.02 in ²	12.85 mm ²	0.02 in ²	12.85 mm ²	0.02 in ²	12.85 mm ²	0.02 in ²
K - Kinetic Nozzle Area	314 mm ²	0.49 in ²	314 mm ²	0.49 in ²	314 mm ²	0.49 in ²	908 mm ²	1.41 in ²
L - Total Width	134 mm	5 1/4"	134 mm	5 1/4"	134 mm	5 1/4"	187 mm	7 3/8"
E - Drainage Diameter	3/4" BSP	3/4" BSP	3/4" BSP	3/4" BSP	3/4" BSP	3/4" BSP	1 1/2" BSP	1 1/2" BSP
Weight	470 g	1.04 lbs.	470 g	1.04 lbs.	470 g	1.04 lbs.	1052 g	2.32 lbs.

Performance:

