

## General Purpose Pressure Gauge: Steel Case

<b>Case and bezel material:</b>	Black Painted Steel
<b>Connection:</b>	Copper alloy
<b>Bourdon tube material:</b>	Copper alloy
<b>Working temperature:</b>	Ambient = -20~60° C, Process = +70° C
<b>Dial:</b>	Black print kPa, Red print PSI (80 & 100mm kPa only) on White Background
<b>Ranges:</b>	-100~0 kPa to dual scale 0~6,000 kPa/PSI (80 & 100mm single scale kPa)
<b>Connection:</b>	¼" BSPT, (100mm is 3/8" BSPT)
<b>Window:</b>	Polycarbonate, (80 & 100mm is Glass)
<b>Surge protection:</b>	Available on Request
<b>Movement:</b>	Copper alloy
<b>Pointer:</b>	Aluminium Black Finish
<b>Accuracy:</b>	+/- 2.5% of Full Scale



Dimensions in mm

	A*	B	C	C1	E	G
<b>50</b>	52.8	45.6	26.4	26.4	9.3	48.5
<b>63</b>	63.2	53.6	29.8	30.0	9.8	52.1
<b>80</b>	77.0	68.2	34.6	32.8	13.0	54.0
<b>100</b>	100.5	80.5	35.5		13.1	

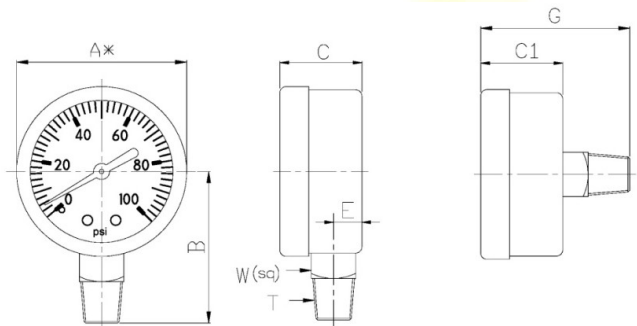

Size	50mm		63mm		80mm		100mm	Accessories
Range (in kPa)	Lower Mount P/N	Centre Back Mount P/N	Lower Mount P/N	Centre Back Mount P/N	Lower Mount P/N	Centre Back Mount P/N	Lower Mount P/N	
-100-0			1612510	1613501 <sub>5</sub>	1616500		1618000	63mm glass lens P/N: 1619950
-100/+150							1618050	
-100/+1600							1618055	
0-100			1612530	1613541 <sub>5</sub>				Restrictor 0.46mm P/N: 1619915
0-250			1612600	1613560	1616600		1618100	
0-400	1611152 <sub>1</sub>		1612730		1616650		1618150	Restrictor 0.25mm P/N: 1619916
0-600			1612740					
0-800	1611261 <sub>3</sub>		1612750		1616700		1618200	
0-1000	1611300 <sub>2</sub>	1612311 <sub>4</sub>	1612770	1613580	1616750		1618250	
0-1600	1611352 <sub>9</sub>	1612402	1612810	1613590	1616800 <sub>7</sub>	1617530 <sub>7</sub>	1618300	100mm back flange P/N: 1619700
0-2500			1612850	1613596 <sub>6</sub>	1616850 <sub>7</sub>	1617550	1618350 <sub>8</sub>	
0-4000			1613150	1613600	1616900		1618400	
0-6000			1613200	1613620				
0-8000	1611800 <sub>1</sub>							
0-16000	1611900 <sub>1</sub>							
0-25000	1611940 <sub>1</sub>							
<b>Weight gms</b>	115	120	146	205	285	225	400	

### Legend

- |                                  |                     |  |
|----------------------------------|---------------------|--|
| 1. Safety pattern case model 512 |                     | 5. Supplied with stainless steel case and front flange model 414 |
| 2. Available in safety pattern   | <b>P/N: 1611301</b> | 6. Supplied with ¼" BSPT   |
| 3. Available in 1/8" BSPT        | <b>P/N: 1611260</b> | 7. Supplied with red line at 970 kPa                             |
| 4. Supplied with 1/8" BSPT       |                     | 8. Available with ½" BSPT  |
|                                  |                     | <b>P/N: 1618352</b>  |
|                                  |                     | 9. Available in safety pattern                                   |
|                                  |                     | <b>P/N: 1611364</b>  |