

ANSI150/ PN16/ JIS10K
SIZE: 1/2"-4"



ZIPSON'S 207S, 2-piece flanged ball valve is designed for most industrial application. 207S designed with ISO direct mounting pad, it's convenient for mounting pneumatic/ electric actuator directly up the valve's ISO pad.

207S offer complete flange connection in ASME/ DIN/ JIS standard. Size range are from 1/2" to 4" (DN15 to Dn100), and fire safe API607-4th Edition Certified for option.

You may need the valve to be with PTFE/ PFA coating on the surface of valve body/ end/ ball/ stem to for anti-sticky function. This will also be convenient to clean the valve just flush by water.

TFM1600/ TFM4215/ UPE (UHMWPE)/ PEEK are available for different application as required. Hastelloy C/ Super Duplex/ Alloy 20/ Monel and other extraordinary steel material are available as asked.

SPECIFICATION

- * Body & end caps quality investment casting
- * Available in stainless steel or carbon steel
- * with ISO 5211 direct mounting pad
- * Adjustable stem packing
- * Blow-out proof stem design
- * 100% air tested under water at 80-100 psi
- * Working pressure: Class150/ PN16/ JIS10K
- * Temperature range -20°F to 450°F

Class150

- * Valve Design: ASME B16.34
- * Steel Casting: MSS SP-55
- * Face to face: ASME B16.10
- * Flange connection: ASME B16.50
- * Pressure test: API 598 (ISO 5208)
- * Sulfide stress cranking: NACE MR-01-75

PN16

- * Valve Design: EN 12516-1
- * Steel Casting: EN 12680-1/ MSS SP-55
- * Face to face: DIN 3202 F4/ F1
- * Flange connection: DIN2633 (PN16)/DIN2635 (PN40)
- * Pressure test: EN12266-1 (ISO 5208)

JIS10K

- * Valve Design: ASME B16.34
- * Steel Casting: MSS SP-55
- * Face to face: JIS B 2002
- * Flange connection: JIS B 2212
- * Pressure test: JIS B 2003 (API 598)

OPTION



- * **FIRE SAFE: API607-5th Edition Certified**
- * TFM1600/ TFM4215/ PEEK/ UPE soft kits
- * Automation application
- * PTFE/ PFA coating (40-70 um)
- * Hastalloy C/ Super duplex/ Alloy 20/ Monel
- * Anti-static devices
- * V-ball for control valve in 15°, 30°, 60°, 90°, slot
- * Flange with Table D, Table E drilling

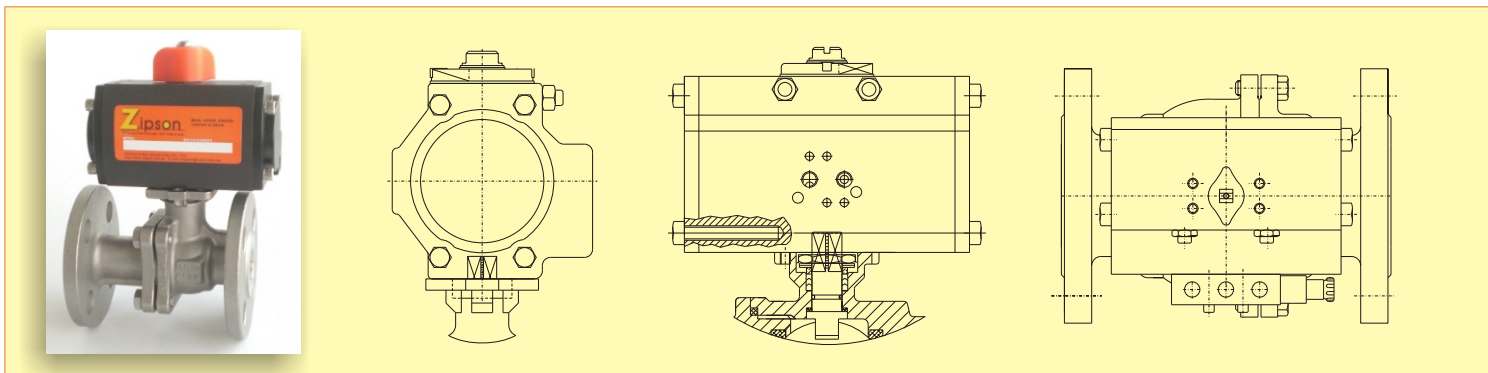

* Pneumatic (DA or SR)/ Electric actuator * Solenoid valve/ Limit Switch Box/ EP

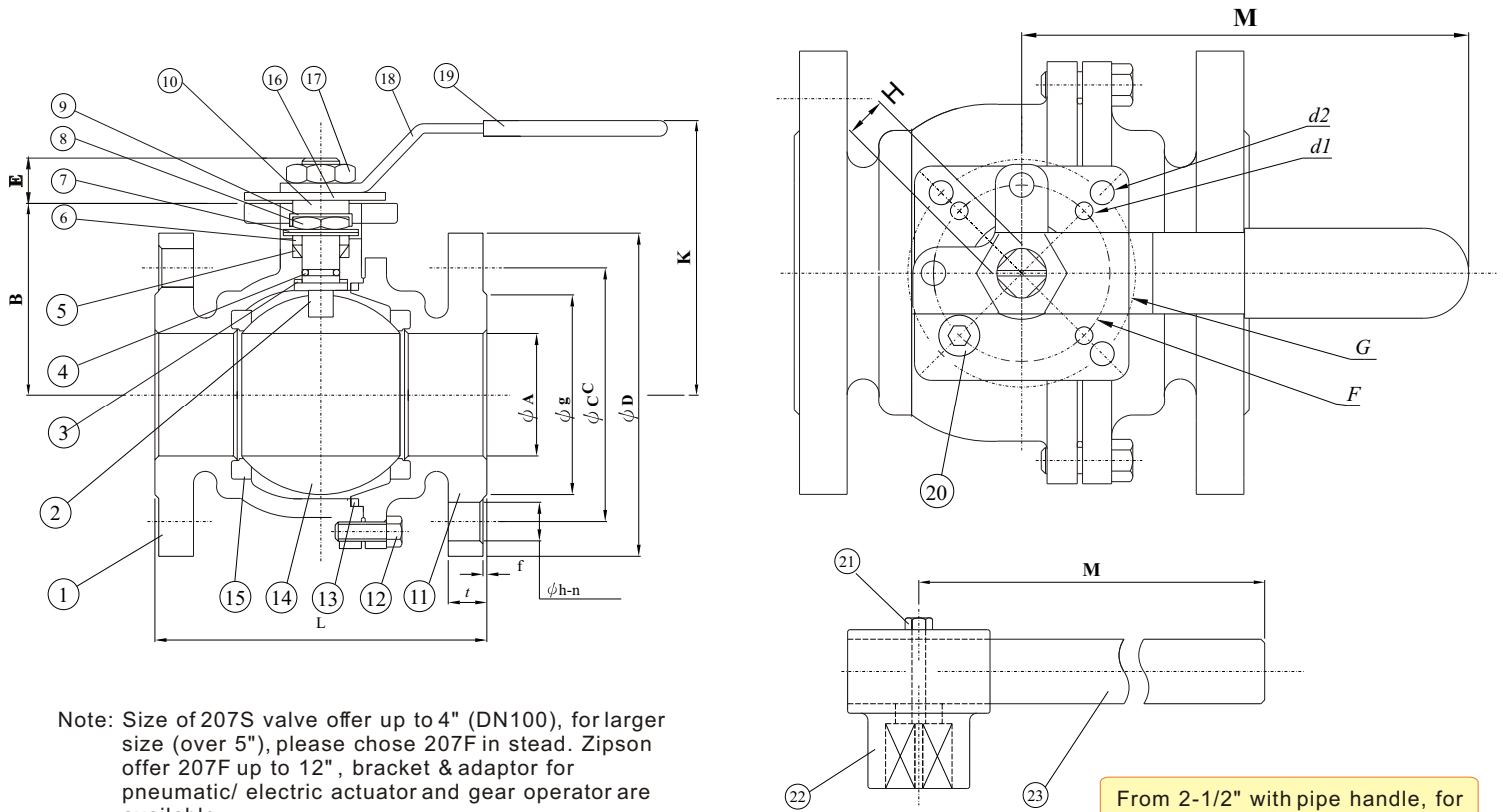

Note: Size of 207S valve offer up to 4" (DN100), for larger size (over 5"), please chose 207F in stead. Zipson offer 207F up to 12", bracket & adaptor for pneumatic/ electric actuator and gear operator are available.

From 2-1/2" with pipe handle, for long term & smooth usage.

DIMENSIONS (mm)/ ASME150

SIZE	A	B	E	L	H	K	M	F	G	d1	d2	CLASS150 FLANGE DIMENSIONS							W (kg)
												D	C	h	N	t	g	f	
1/2"	15	48	11	108	9	80	130	36	42	6	6	89	60.5	16	4	11.5	35	1.6	1.73
3/4"	20	53	11	117	9	80	130	36	42	6	6	98	70	16	4	11.5	43	1.6	2.13
1"	25	59	14	127	11	90	165	42	50	6	7	108	79.5	16	4	11.5	51	1.6	2.92
1-1/4"	32	71	14	140	11	102	165	42	50	6	7	117	89	16	4	12.7	64	1.6	4.02
1-1/2"	38	76	18	165	14	110	205	50	70	7	9.2	127	98.5	16	4	14.3	73	1.6	5.90
2"	50	85	18	178	14	120	205	50	70	7	9.2	152	120.5	19	4	15.9	92	1.6	8.72
2-1/2"	65	93.5	23	190	17	140	300	70	102	9.2	11.4	178	139.5	19	4	17.8	105	1.6	13.33
3"	80	103	23	203	17	150	340	70	102	9.2	11.4	190	152.5	19	4	19.1	127	1.6	17.03
4"	100	132	25	229	22	180	420	102	125	11.4	13.5	229	190.5	19	8	24.0	157	1.6	28.98

DIMENSIONS (mm)/ PN16

SIZE	A	B	E	L	H	K	M	F	G	d1	d2	PN16 FLANGE DIMENSIONS							W (kg)
												D	C	h	N	t	g	f	
1/2"	15	48	11	115	9	80	130	36	42	6	6	95	65	14	4	14	45	2	2.13
3/4"	20	53	11	120	9	80	130	36	42	6	6	105	75	14	4	16	58	2	2.85
1"	25	59	14	125	11	90	165	42	50	6	7	115	85	14	4	16	68	2	3.72
1-1/4"	32	71	14	130	11	102	165	42	50	6	7	140	100	18	4	16	78	2	5.32
1-1/2"	38	76	18	140	14	110	205	50	70	7	9.2	150	110	18	4	16	88	3	6.96
2"	50	85	18	150	14	120	205	50	70	7	9.2	165	125	18	4	18	102	3	9.68
2-1/2"	65	93.5	23	170	17	140	300	70	102	9.2	11.4	185	145	18	4	18	122	3	13.49
3"	80	103	23	180	17	150	340	70	102	9.2	11.4	200	160	18	8	20	138	3	17.53
4"	100	132	25	190	22	180	420	102	125	11.4	13.5	220	180	18	8	20	158	3	25.62

DIMENSIONS (mm)/ JIS10K

SIZE	A	B	E	L	H	K	M	F	G	d1	d2	JIS10K FLANGE DIMENSIONS							W (kg)
												D	C	H	N	t	g	f	
1/2"	15	48	11	110	9	80	130	36	42	6	6	95	70	15	4	12	52	1.0	1.92
3/4"	20	53	11	120	9	80	130	36	42	6	6	100	75	15	4	14	58	1.0	2.46
1"	25	59	14	130	11	90	165	42	50	6	7	125	90	19	4	14	70	1.0	3.88
1-1/4"	32	71	14	140	11	102	165	42	50	6	7	135	100	19	4	16	80	2.0	4.74
1-1/2"	38	76	18	165	14	110	205	50	70	7	9.2	140	105	19	4	16	85	2.0	6.30
2"	50	85	18	180	14	120	205	50	70	7	9.2	155	120	19	4	16	100	2.0	8.48
2-1/2"	65	93.5	23	190	17	140	300	70	102	9.2	11.4	175	140	19	4	18	120	2.0	14.33
3"	80	103	23	200	17	150	340	70	102	9.2	11.4	185	150	19	8	18	130	2.0	18.92
4"	100	132	25	230	22	180	420	102	125	11.4	13.5	210	175	19	8	18	155	2.0	34.21

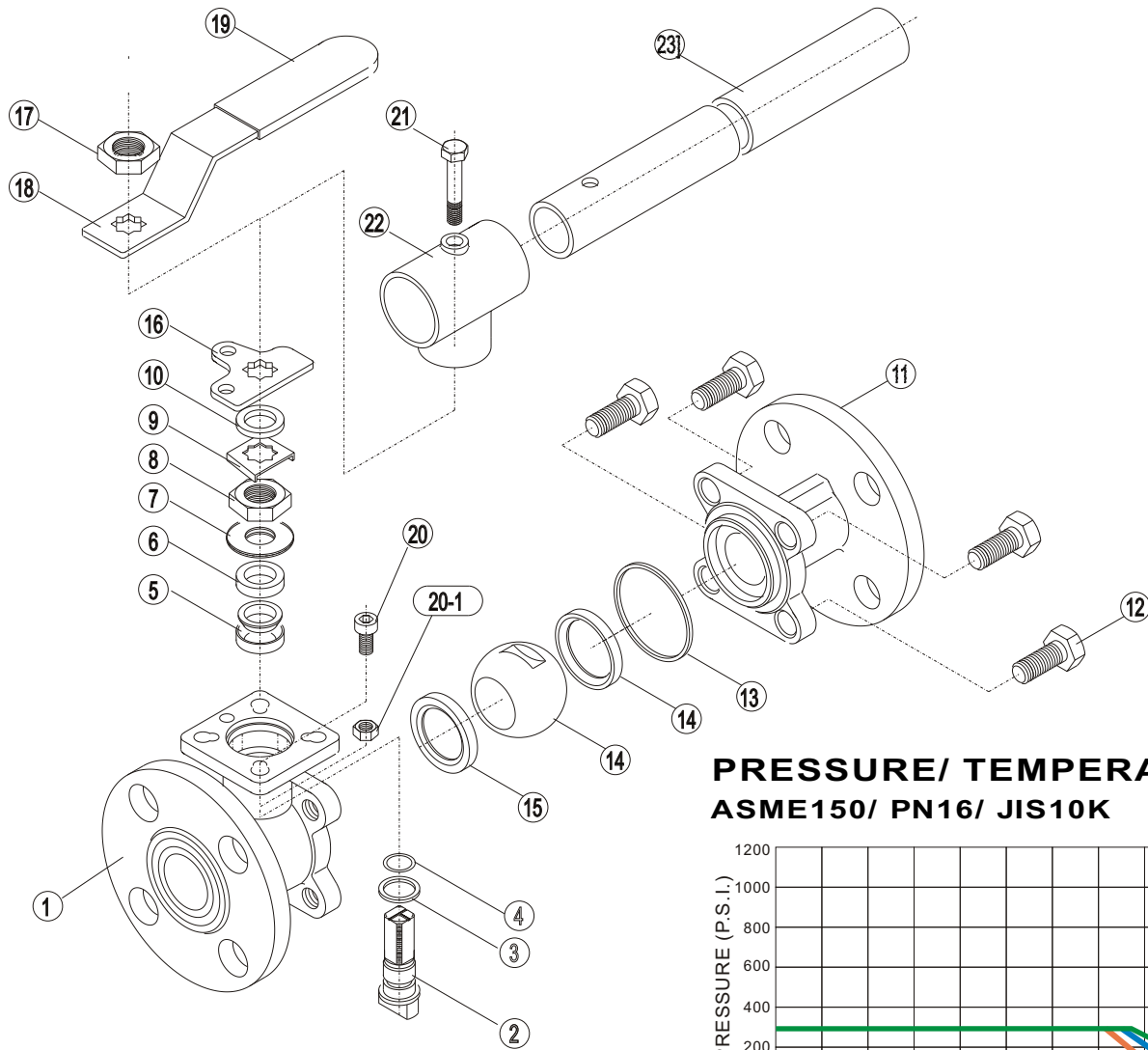

PRESSURE/ TEMPERATURE ASME150/ PN16/ JIS10K

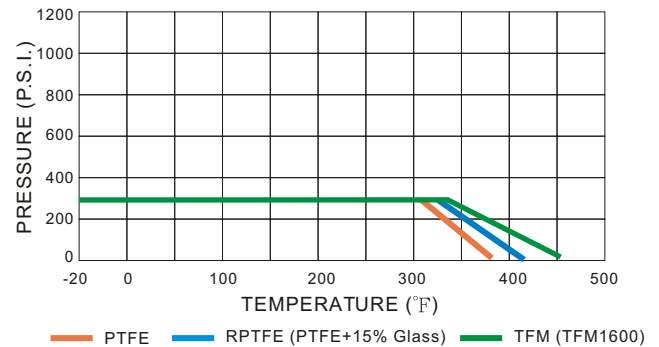

BREAK-TORQUE VALUE for ASME150/ PN16/ JIS10K (Nm/ at 0 psi)

SIZE	1/2"	3/4"	1"	1 1/4"	1 1/2"	2"	2-1/2"	3"	4"
GREASE	5.5	7.2	8.8	13	20	24	54	62	124
NON-GREASE	7.2	9.4	13.2	18.2	30	36	95	132	245

MATERIALS LIST (ASME150/ PN16/ JIS10K)

ITEM	PART NAME	MATERIAL		
		CLASS150	PN16	JIS10K
1	BODY	CF8M/ WCB	1.4408/ 1.0619	SCS14/ SCPH2
2	STEM	SS 316/ SS 304	SS 316/ SS 304	SS 316/ SS 304
3	THRUST WASHER	RPTFE	RPTFE	RPTFE
4	O-RING	VITON	VITON	VITON
5	STEM PACKING	PTFE	PTFE	PTFE
6	GLAND	SS 304	SS 304	SS 304
7	DISK WASHER	SS 301	SS 301	SS 301
8	STEM NUT	SS 304	SS 304	SS 304
9	NUT STOP	SS 304	SS 304	SS 304
10	WASHER	SS 304	SS 304	SS 304
11	FLANGED END	CF8M/ WCB	1.4408/ 1.0619	SCS14/ SCPH2
12	BOLT	SS 304	SS 304	SS 304
13	GASKET	PTFE	PTFE	PTFE
14	BALL	SS 316/ SS 304	SS 316/ SS 304	SS 316/ SS 304
15	BALL SEAT	PTFE/RPTFE	PTFE/RPTFE	PTFE/RPTFE
16	STOPPER PLATE	SS 304	SS 304	SS 304
17	HANDLE NUT	SS 304	SS 304	SS 304
18	HANDLE	SS 304	SS 304	SS 304
19	SLEEVE	PLASTIC	PLASTIC	PLASTIC
20	STOP PIN	SS 304	SS 304	SS 304
21	SET BOLT	SS 304	SS 304	SS 304
22	LEVER HEAD	CF8	CF8	CF8
23	PIPE HANDLE	STEEL PIPE	STEEL PIPE	STEEL PIPE

Note: The greases ZIPSON use including lubricant & anti-seize grease are both SILICONE-FREE.